

smart **P**ARK

GROUP 6

Sponsored By:
 **BOEING**

Team



smart **P**ARK

HEATH  **DITTMAN**

ROBERT  **MONTALBANO**

CARLOS  **VENTURA**

Motivation

- University of Central Florida is the Second largest school in the United States by enrollment. With over sixty thousand students and less than half in parking, students waste countless hours looking for a place to park.
- Due to this parking dilemma, the garages and roadways are always congested, accidents are prone to happen and students are often late to class.
- The green permits parking locations are designated for student use. Currently, there are 27,295 green permit holders and only 12,500 parking spots for them.

Goals

- By introducing smartPARK, we not only plan to revolutionize the way students park but we will make our parking lots and garages safer. SmartPark will be a user friendly mobile application which will provide drivers a series of information regarding their destination's parking location.
- smartPARK will use a series of cameras with wide angle lenses, strategically located to capture the parking location with clear visibility of the individual parking spots. The camera will deliver a live feed to a remote server running an application which will determine the parking lot space availability, keep track of other useful data and forward that information to the end user's mobile device.

Block Diagram

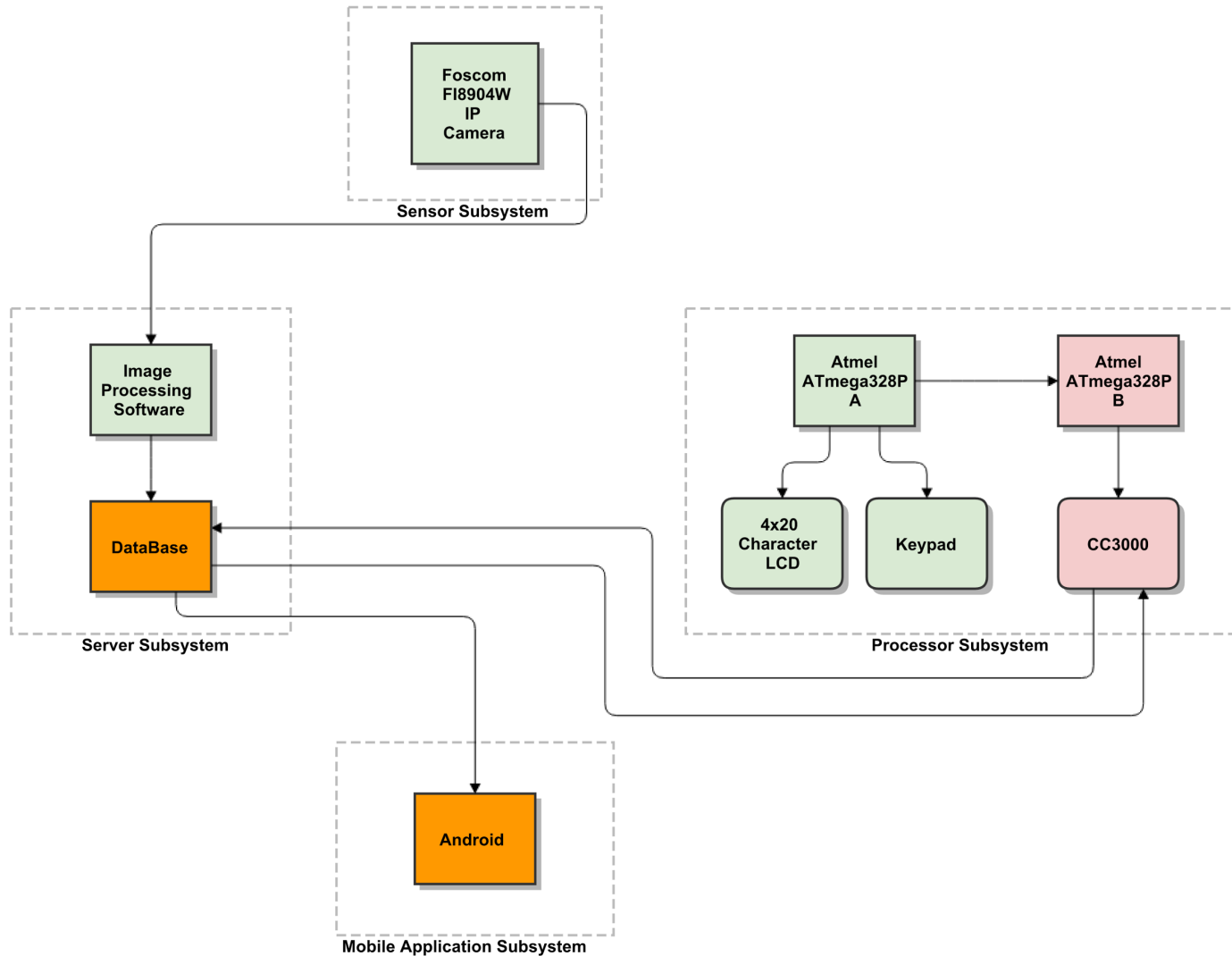

Specification

The smartPARK system must achieve the following:

- The video stream from the IP Camera must provide the server with one frame per second for image analysis.
- Image Analysis Software must be able to determine the availability of a parking location.
- Database must store parking location information and be accessible within ten seconds of a real time change in parking conditions.
- Mobile application must be clean, simple and user friendly.
- Our battery power must last at least four hours with continuous use.

IP Camera

Foscam FI8904W

- 640 x 480 Pixels (300k Pixels) Max
 - 15fps @ VGA
 - 30fps @ QVGA
- IEEE 802.11b/g
- 24 IR LEDs
- Night Visibility of approx 20 meters
- MJPEG Image Compression
 - Broadcasted stream of JPEGs
- Weather Resistant Housing
 - 2.5 lbs



Image Processing

Pixel Intensity Value Comparison (Java)	Object Detection OpenCV (C++/Java)
Scalable sensitivity through thresholding	Highly dependant on distance from target
Very few false negative conditions	Susceptible to false Negatives
A group member with some basic experience in Java	Entire group is unfamiliar with C++/OpenCV
Java	C++
OpenCV Shell, JavaCV	Native Platform for OpenCV

Image Processing

- Calibration Image
 - Image of monitored where all spaces are empty
- Obtaining Images from the Camera
 - Retrieve a single frame of data per second for Analysis
- Identifying Regions of Interest



- Horizontal RoI Pixels: 302 - 396
- Vertical RoI Pixels: 318 - 443

Image Processing

Approach:

1. Pixel Intensity Value

Color Image (0-255)

- Red
- Green
- Blue

Grayscale (0-255)

- Gray

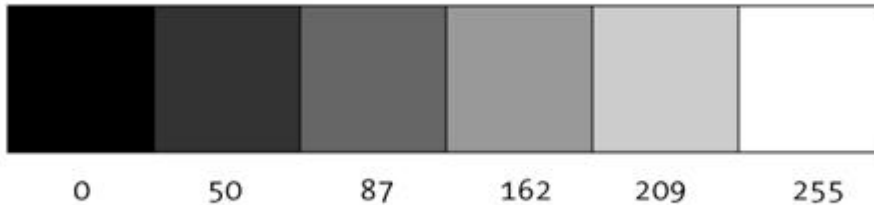
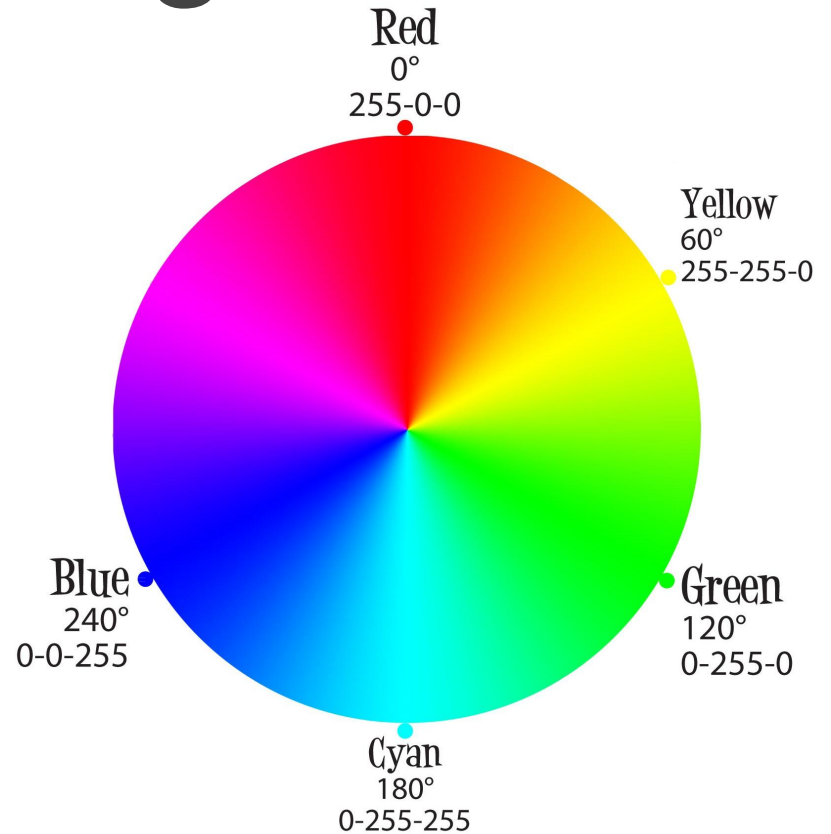

Image Processing

Varying conditions effecting thresholding

- Lighting
 - Shade
 - Day
 - Night
 - Raining conditions
- Differences in viewing angles
 - Close viewing angle monitoring a smaller parking area
 - Very accurate
 - Longer viewing angle enabling the monitoring of many more parking locations
 - Less accurate



Image Processing

Likely Design Problems:

- The inconsistency of natural lighting will affect readings
 - Daily thunderstorm
- Cars of similar color to pavement might not be detected
- None-Vehicle objects causing false positive readings
- Small Vehicle causing false negative readings

Parking Terminal

Hardware

- MicroController
 - 2 - Atmega328P-Pu
 - Adafruit CC3000
- Key Pad
 - 12 Tactile Switches
 - 3 x 4 Array
 - 4 x 20 LCD Screen
- Monitor
 - LCD Monitor
 - Driven by Web Application
 - Parking View



Parking Terminal

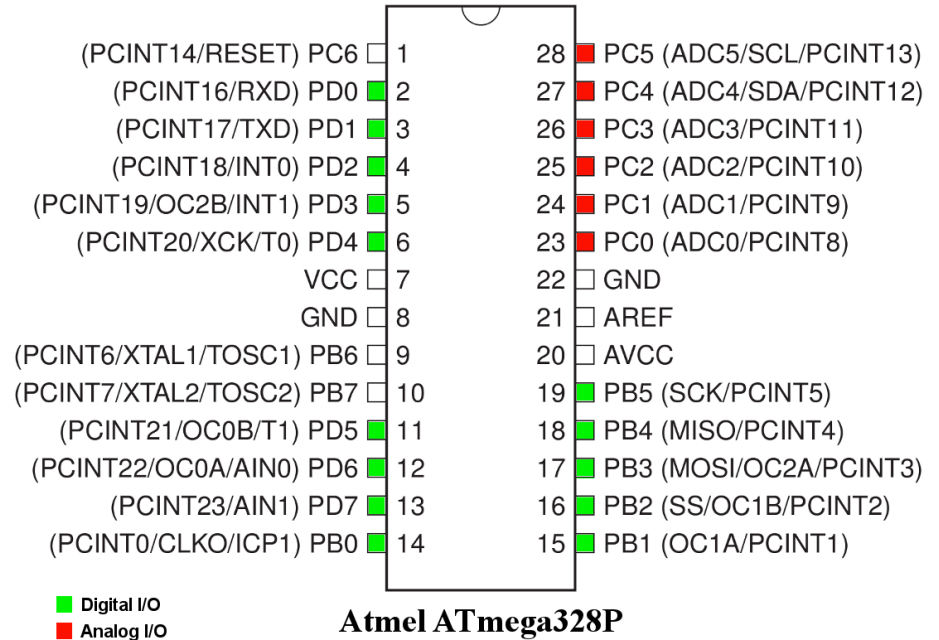

Atmega328P-PU

Data Bus Width:	8-Bit
Max Clock Freq:	20MHz
Program Memory:	32kB
Data RAM:	2kB
Data ROM:	1kB
Operating	
Supply Voltage:	1.8V - 5.5V
Operating Temp:	-40C - 85C
Mount:	Through Hole
Data RAM:	SRAM
Data ROM:	EEPROM
Interface Type:	I2C, SPI, USART
# Programmable I/O:	23
Timers:	3
Program Mem Type:	FLASH



Parking Terminal

Schematic symbol for a button

-  Open / Released
-  Closed / Pressed

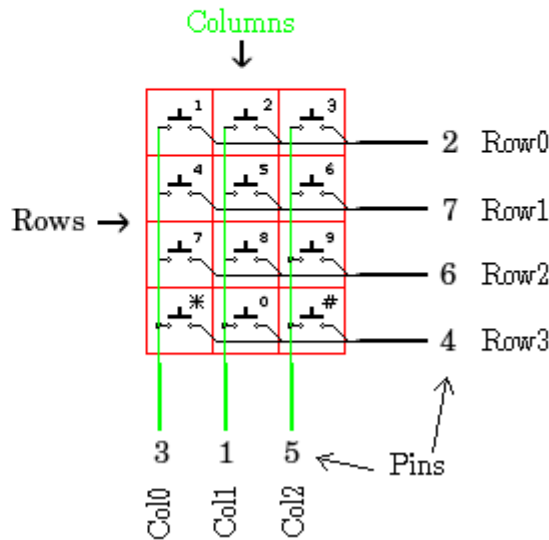

Transceiver

- Requirements
 - Communicate between the camera, server and parking terminal
 - Works with compact memory footprint
 - Integrated crystal and power management
 - Small form factor: 16.3 mm × 13.5 mm × 2 mm
 - Powered by battery
 - Operating temperature: -20°C to 70°C

Adafruit CC3000

- IEEE 802.11 b/g Protocol
- FCC, IC, and CE certified with a chip antenna
- Supports all Wi-Fi security modes for personal networks: WEP, WPA, and WPA2
- Integrated IPv4 TCP/IP stack with BSD socket APIs enables simple internet connectivity with any microcontroller, microprocessor, or ASIC.
- Large support community
- Ease of use

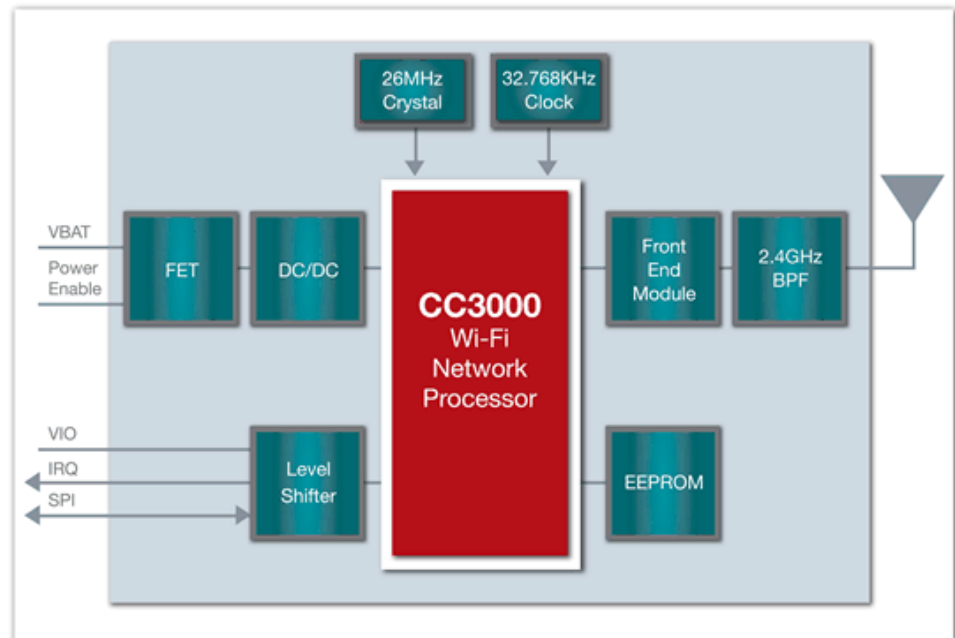

Parking Terminal

Software FlowChart

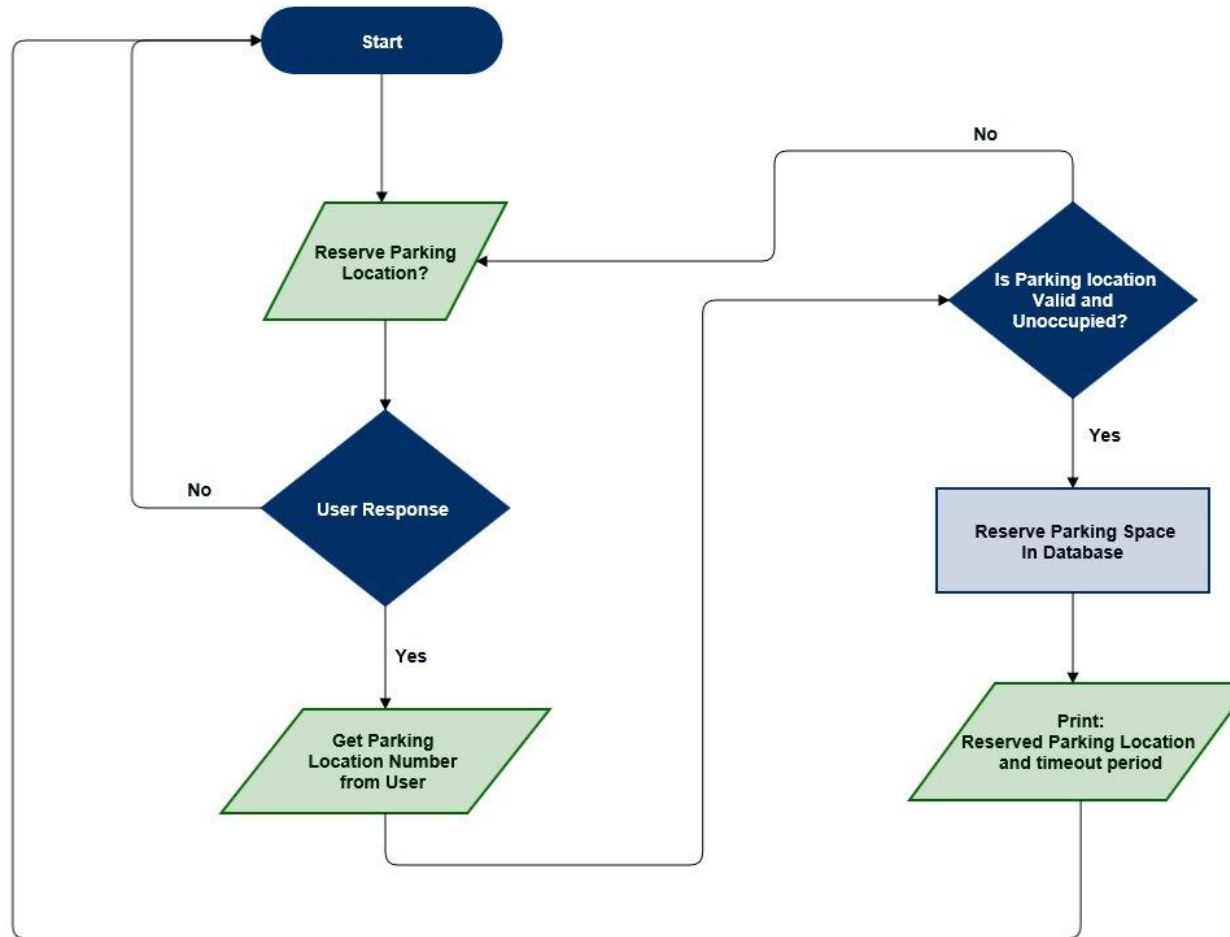

Server Subsystem

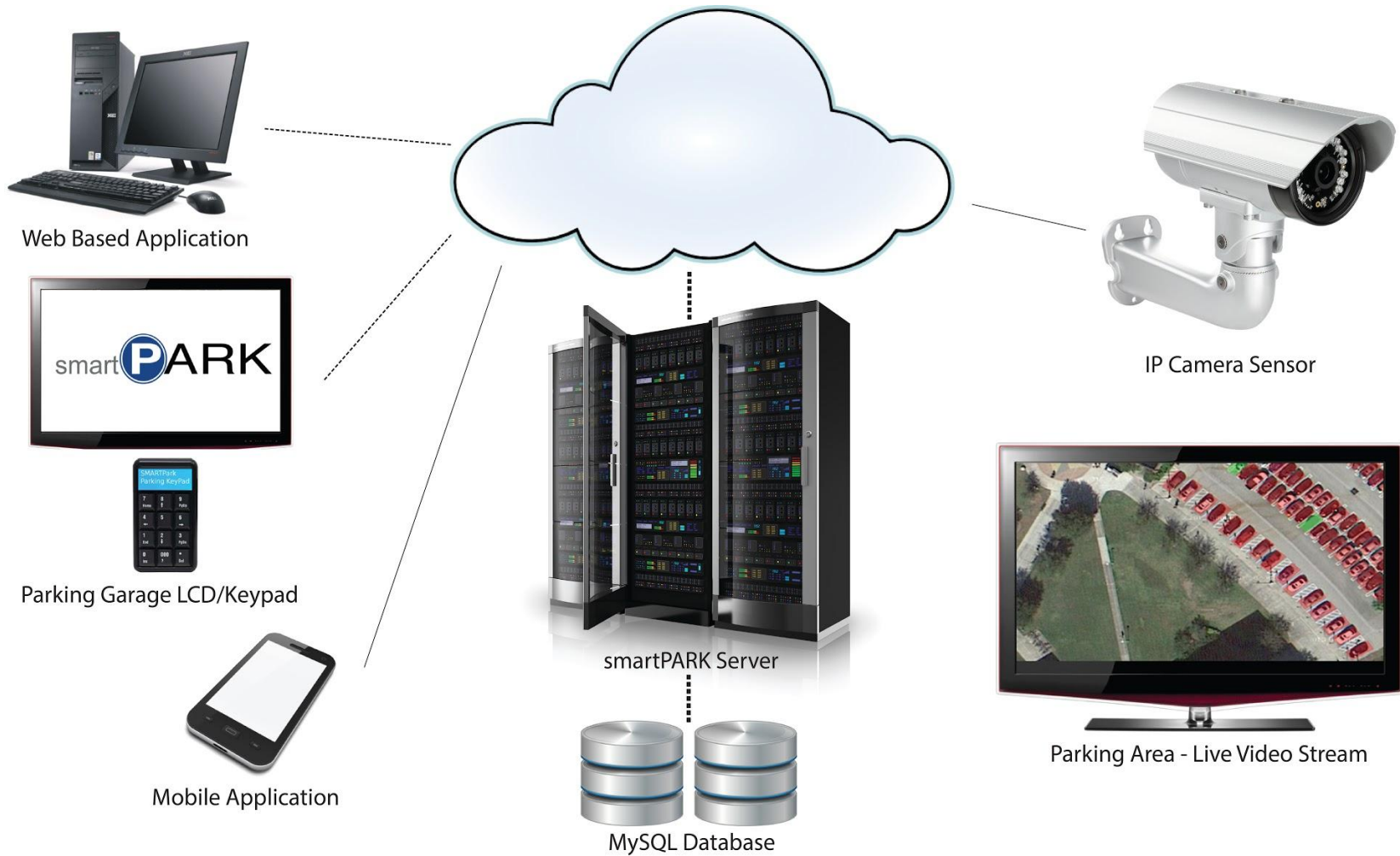

Server VM

- Multiple group members required use of the Server simultaneously. Using different machines was obvious idea, but would not consider server specifications.
- Machine Virtualization is the solution. Creating a Virtual Machine with the exact specifications of the server in regards to both Hardware and Software and then cloning the VM give the team freedom to work independently with identical server environment.
- Master Virtual Machine will be held to merge all of the software developed by the team. Once complete, this Virtual Machine will be saved as the image that will be installed on the actual server.

Server HW

- Existing Hardware used for server is a Dell Inspiron Laptop
- Specifications:

Processor Type	Intel Core 2 Duo T7250
Processor Speed	2.1 GHz
Memory	3GB DDR2 SDRAM
Hard Drive	120 GB SATA
Ethernet Type	10/100 Mbps
Wireless	802.11 a/b/g

Server SW

- Software applications used and developed for the smartPARK require the bare minimum in regards to system resources.
- This gives the smartPARK team the freedom of using software that does not require the latest state of the art technology.
- The operating system that will be used in the smartPARK system is the latest version of the Linux distribution, Ubuntu version 14.04
- The Ubuntu is an Operating System that requires very little system resources and is also open source, a perfect fit for our budget.

VPN

- A Virtual Private Network enables the smartPARK team to gain access of their already developed private network over a public network (the internet)
- A Virtual Private Network will allow us to access the smartPARK private network, which includes the server, IP Camera and other devices, remotely.
- For our final project, it is planned to have all of the subsystems on the same network, but during the implementation, use of a VPN will be required.
- OpenVPN is the VPN is the open source system that has been installed on the server. The client and server certificates have been created and connection to the VPN has been successful.

MySQL Database

- Local storage location of all of the data collected from the image processing software.
- Using MySQL database can be accessed remotely if it becomes necessary.
- Plan on storing unique two dimensional arrays that would tailor to each parking location depending on its size and shape.
- Basic Parking location information will be preloaded into each individual corresponding parking lot table.
- The two dimensional array would hold values of 1's and 0's defining if whether or not a parking spot has been occupied.

MySQL Database

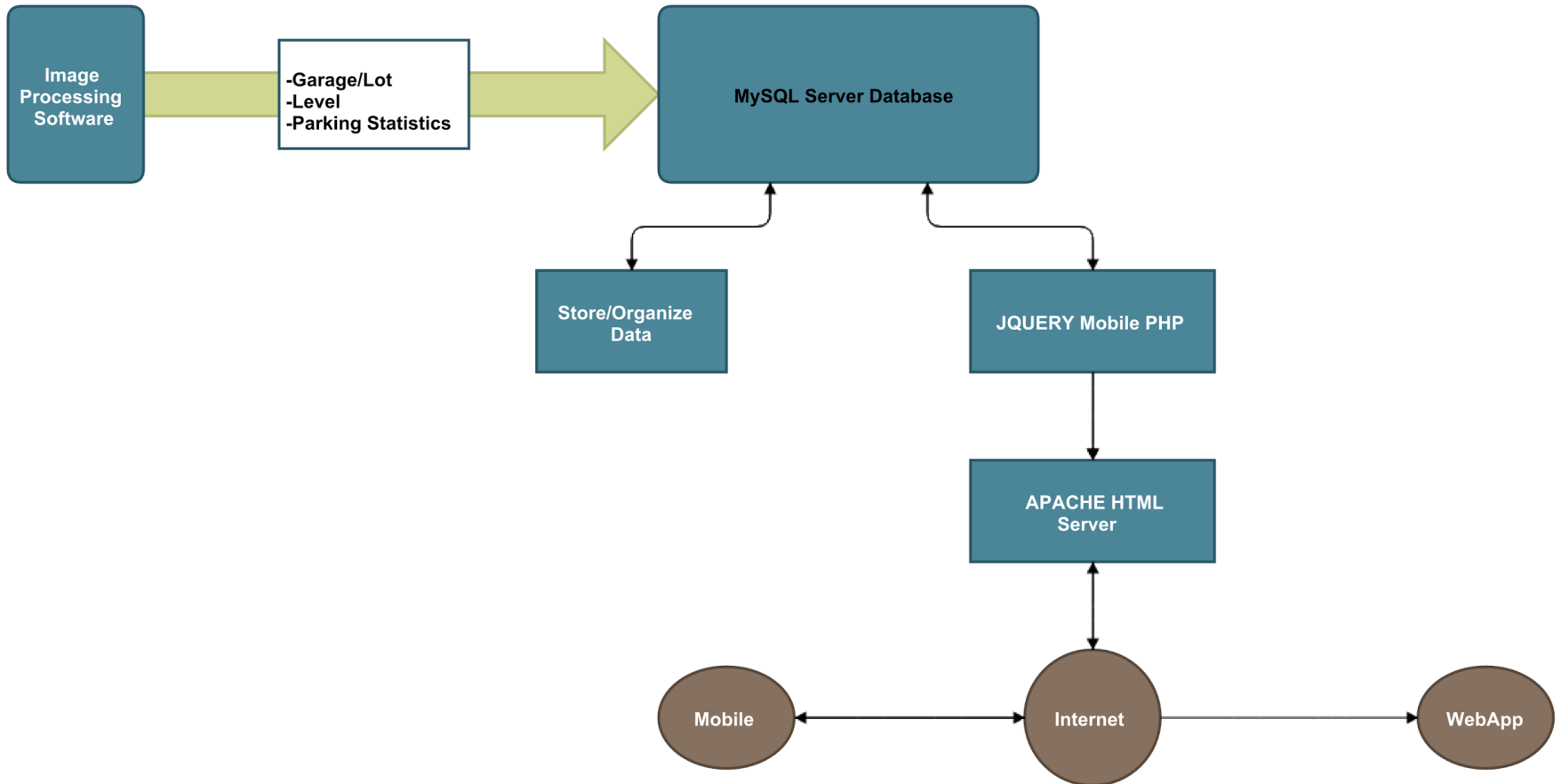

MySQL Database

- Occupied Parking spots would be represented with a 1 and unoccupied with 0's



1 1 0 1 1 0 1 0 0 1 1 1 1 0 1 0 1

1 1 1 1 1 1 1 1 1 0 1 1 0 1 0 1

1 1 1 1 1 0 0 0 1 0 0 0 0 0 0 1

Parking Lot 2D Array Representation

Apache HTTP Server

- The end user will have the ability to access the smartPARK user interface via web or mobile application.
- The smartPARK server will be transferring the information held in the database into a friendly graphical user interface
- The server will also play the role of our web server, hosting all of the information that will be sent to the web and mobile applications.
- Apache HTML Server gives us the ability to host all of the information necessary to provide the user with the ultimate experience.
- Virtual Hosting is another feature available with Apache, which allows for one installation to serve multiple websites simultaneously.

Mobile Application

- The main objective behind smartPARK is to provide the user with a smooth parking experience. Part of this experience is the ability to easily interact with the user interface allowing for rapid parking spot discoveries.
- The application has been designed to be very minimalist while including all of the tools the user needs to easily find a spot.
- The user will be able to select which parking lot or garage they are interested in and instantaneously view parking lot statistics.
- The ability to have the application automatically select which parking lot you are in using GPS is an optional feature we plan to implement if time permits.

Mobile Application

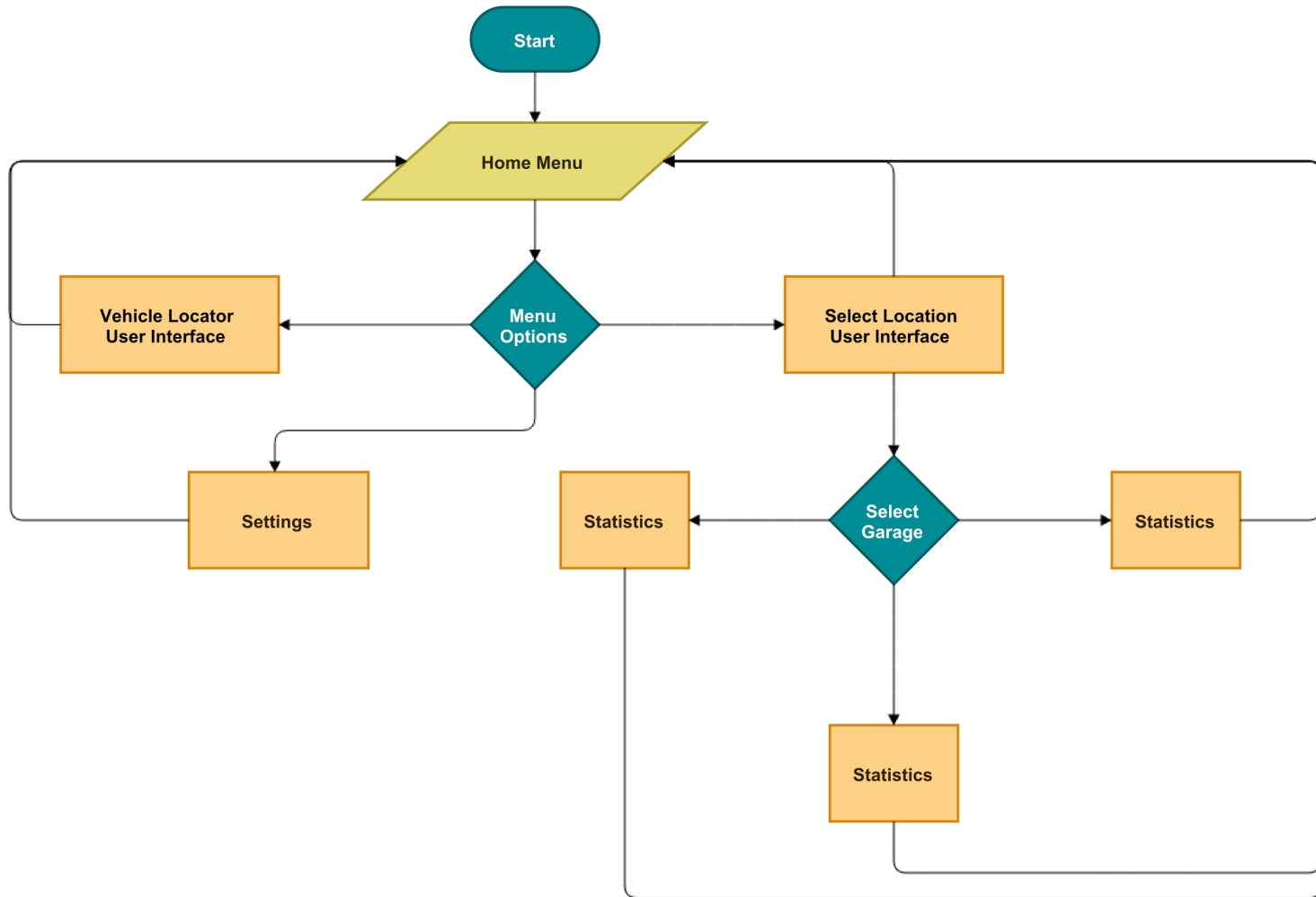

Mobile Application



Mobile Application



Printed Circuit Board

- Custom PCBs

- Designed in Eagle 6.5
- Ordered through Advanced Circuits
- Components ordered through Mouser and Sparkfun Electronics
- Boards assembled by QMS Inc in Lake Mary as well as Team DMV

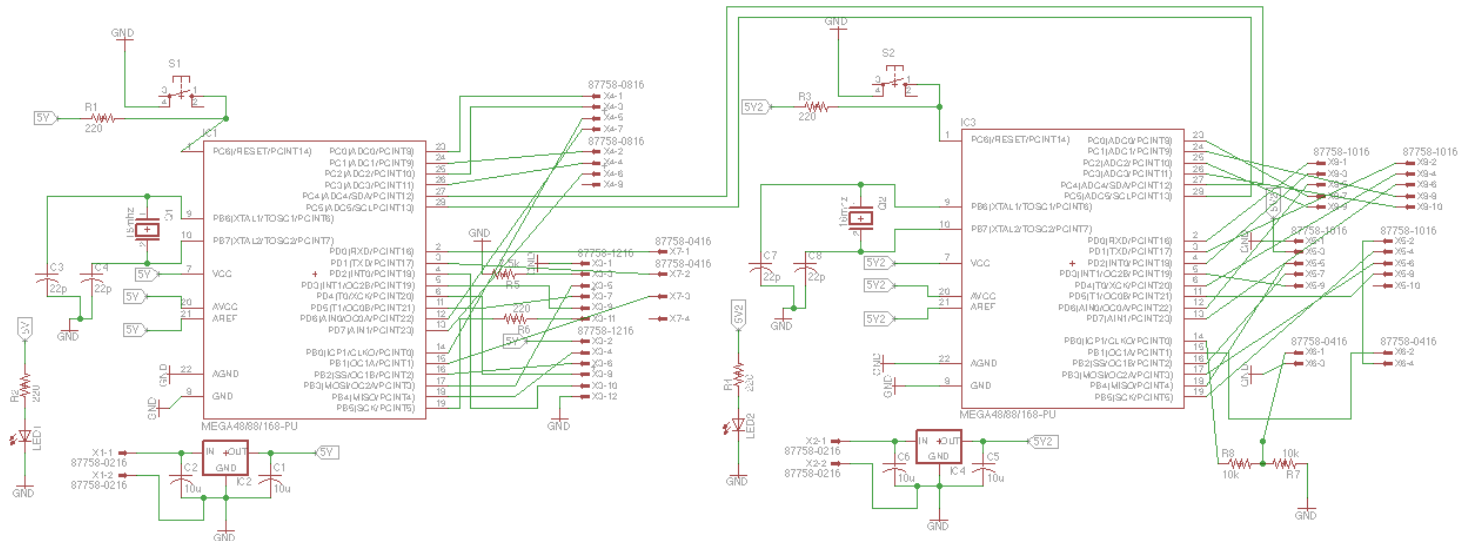

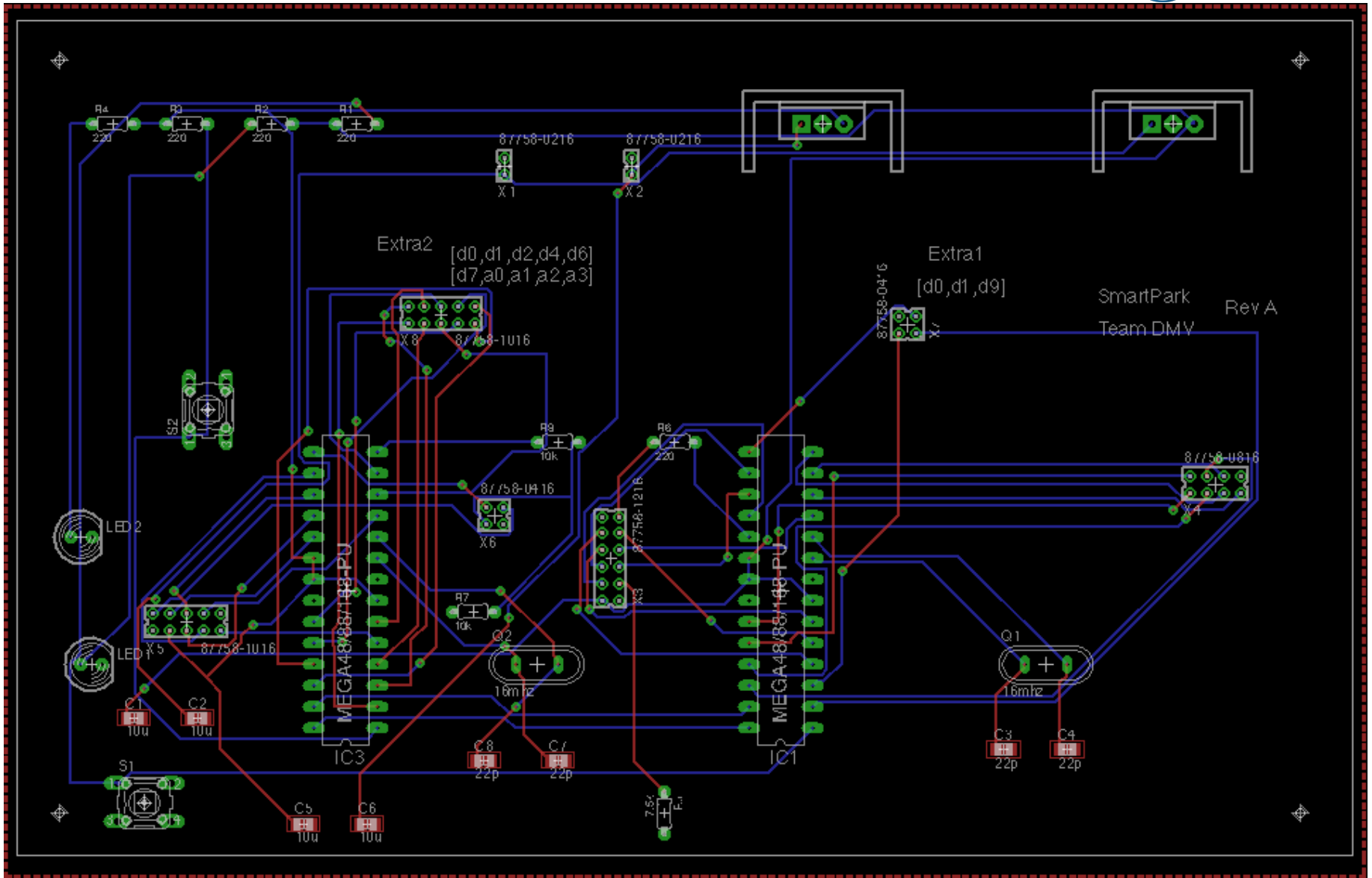

Printed Circuit Boards smart PARK

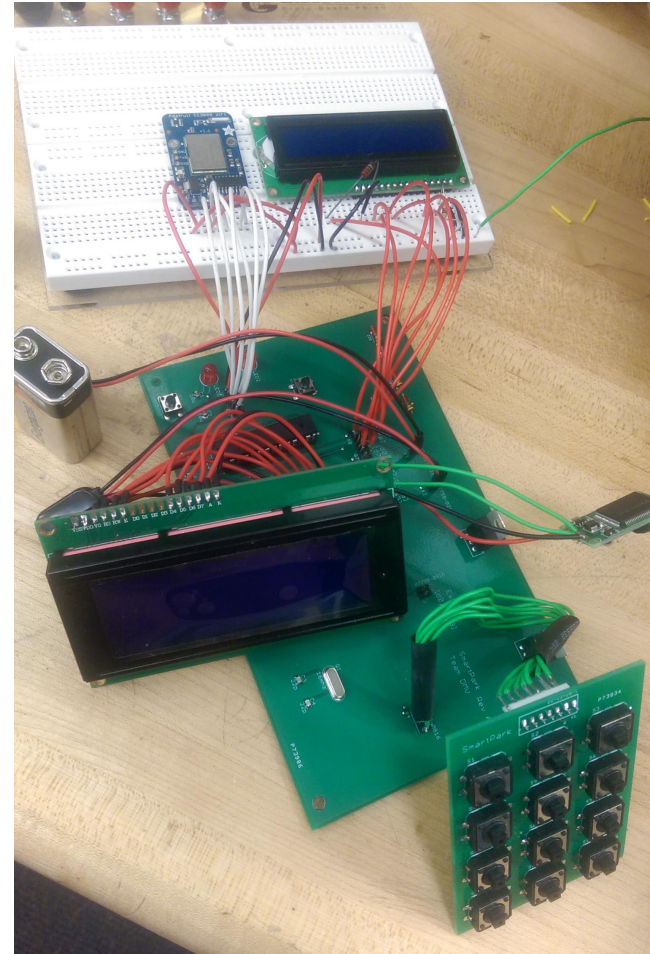
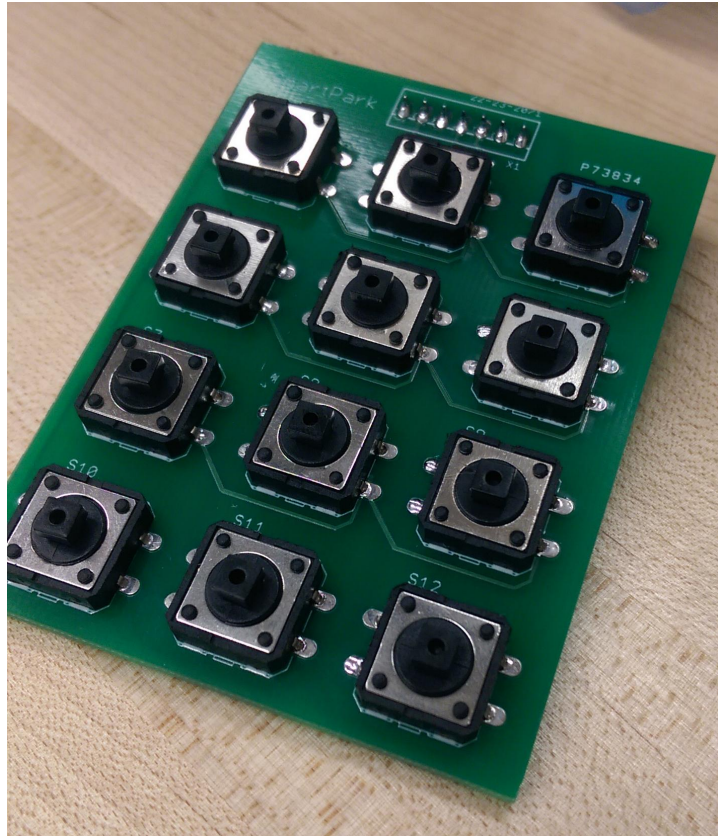

Power System

- Camera/Router
 - Battery
 - Photovoltaic Panel
 - Mobility
 - Scalability
- PCB-MCU/Wireless Module
 - Battery
 - Mobility



Power System

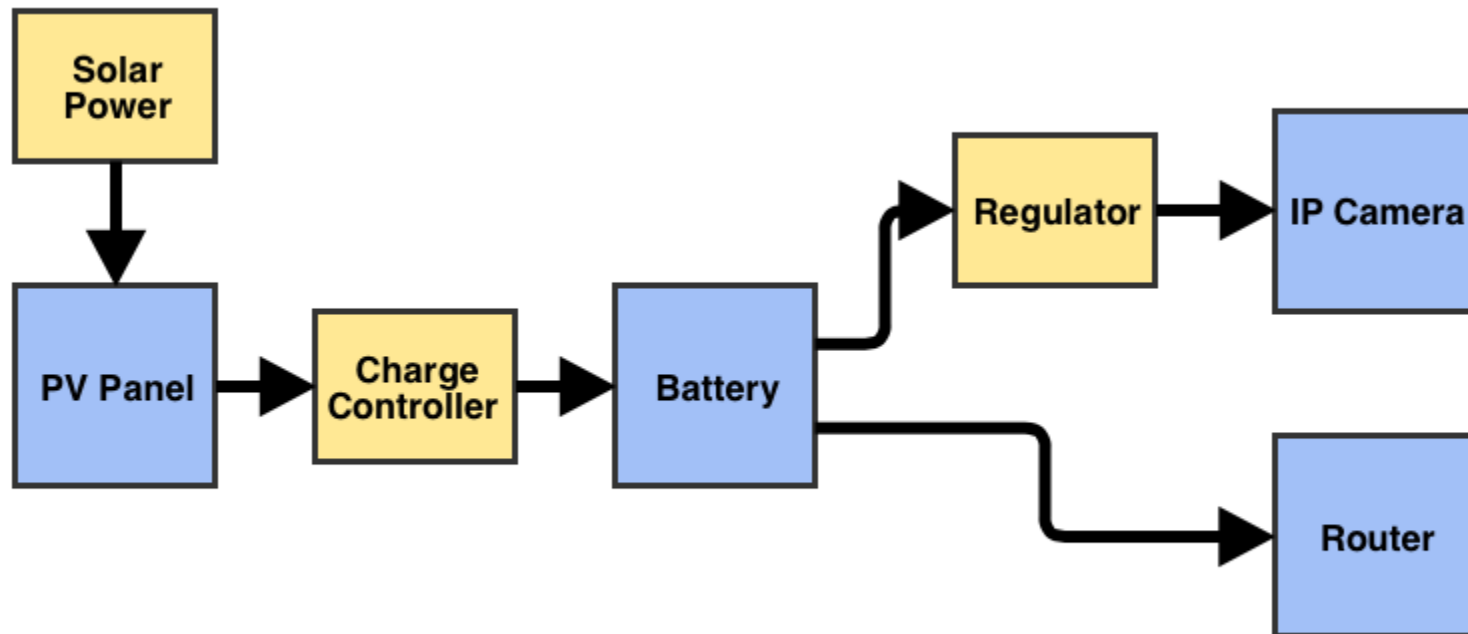

Photovoltaic Panel

- Solartech SPM010P
- Polycrystalline solar panel
- 10W Power Output
- Max Voltage 17.3V
- Max Amperage 0.59A
- 14.5 in x 12.2 in x .7 in



Battery

- Enough charge to power camera and wireless transmission for 4 hours.
- Meets voltage and current requirements of camera.
- VRLA (Valve Regulated Lead Acid) battery will be used due to:
 - High Reliability
 - Quick Chargeability
 - Long Service Life
 - High Power Density
 - Low Maintenance
 - Low Cost
- Werker WKA12-8F
- 12V 8Ah VRLA Battery
- 4lbs

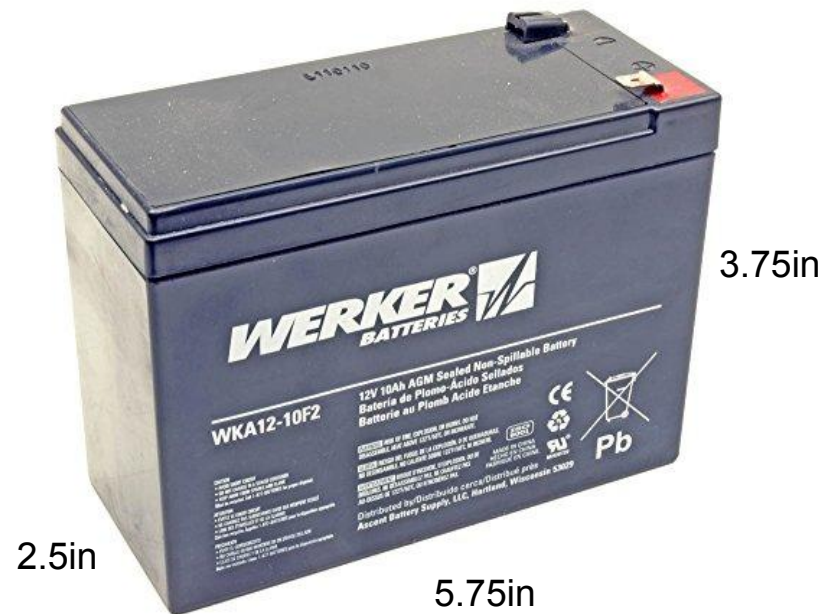

Switcher

- Allow the camera and wireless transmission to run on mains power while available, and switch to battery backup when unavailable.
- Two possible solutions were the UC27131 from TI and the LTC4412 from Linear Technology.
- The LTC4412 was chosen for its logical switching between power sources.

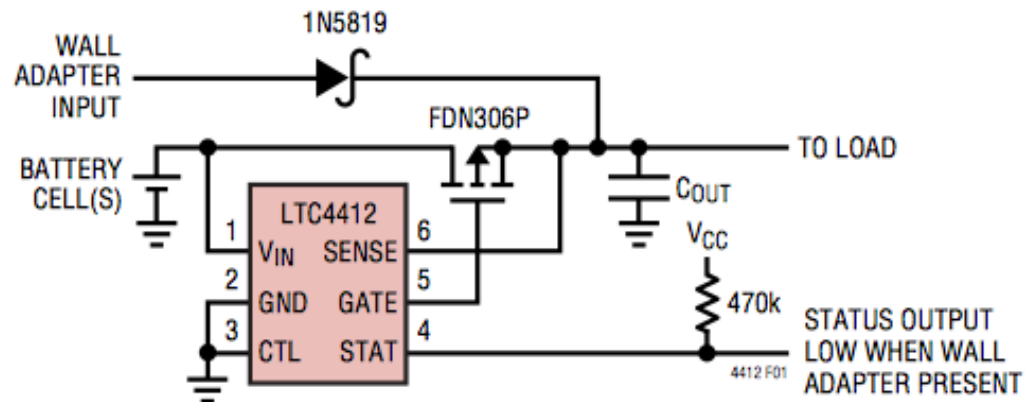

Regulator

LM25118 is a wide voltage range Buck-Boost switching regulator controller.

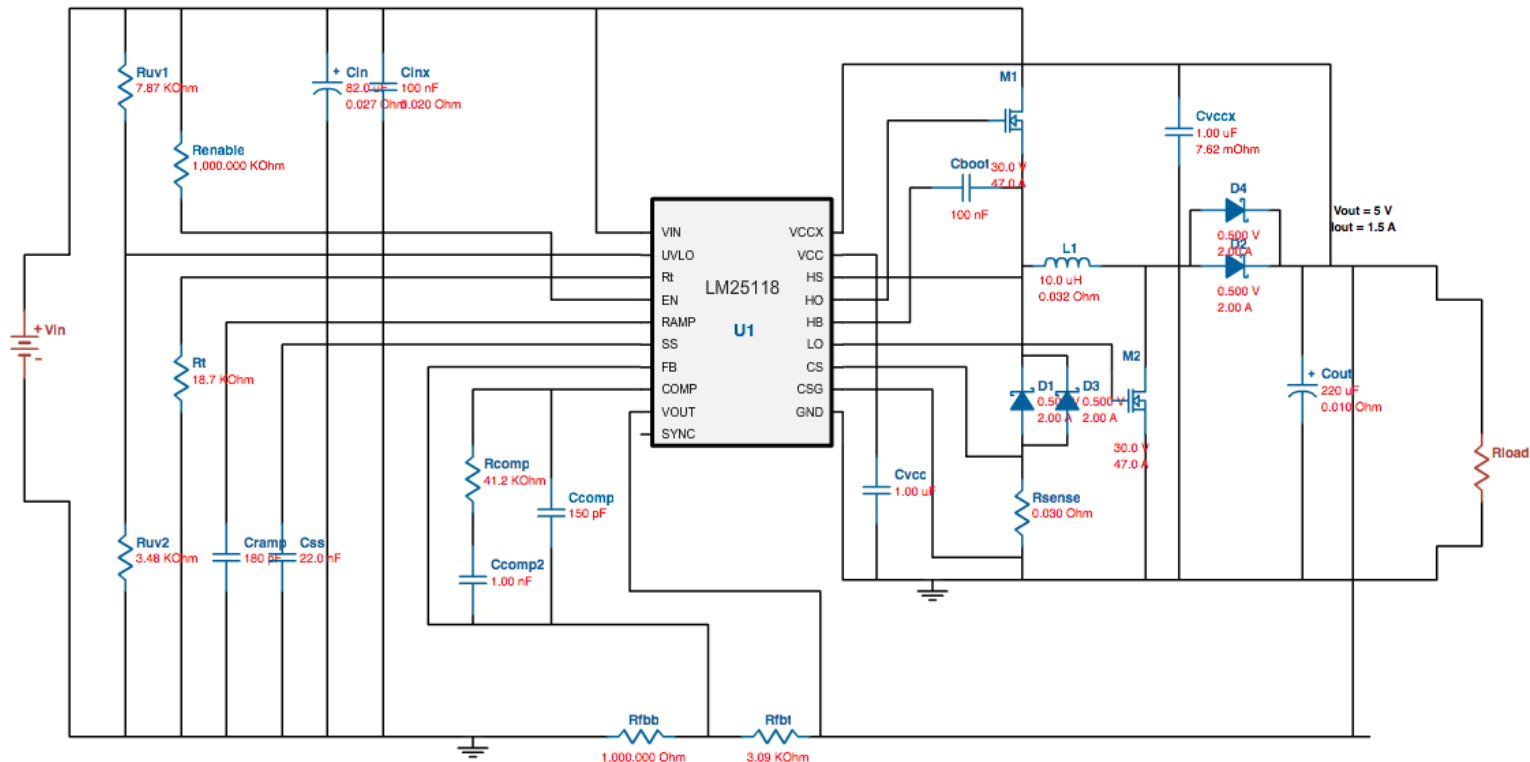

Parts Overview

- 2 Atmega 328P-PU
- Linksys WRK54G
- Adafruit CC3000
- Foscam FI8904W
- Solartech SPM010P
- Werker WKA12-8F
- LTC4412 Switcher*
- LM25118 Regulator*

Budget

Total Estimated Budget	\$688.90
Current Spending	\$736.00
Unexpected Savings	\$56.99
Over Budget	\$47.10

Work Distribution

	Image Recognition	Database	Mobile/Web App	Keypad/PCB	Power
HEATH				X	X
ROBERT	X			X	
CARLOS		X	X		

Questions?