



# Reverse RFID Tracking System

Group 7

Daniel DeFazio

Matthew Rhodes

Brandon Tuero

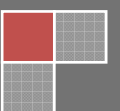

## Table of Contents

Executive Summary.....	1
1.0 Project Description.....	2
1.1 Motivation.....	2
1.2 Goals and Objectives.....	3
1.3 Requirements and Specifications.....	3
1.3.1 Tag (ALN-9640).....	3
1.3.2 Reader Unit .....	4
2.0 Research.....	5
2.1 RFID Technology Overview .....	5
2.1.1 RFID Applications .....	5
2.1.2 Frequency.....	6
2.2 Tags .....	8
2.2.1 Passive UHF Tags.....	8
2.2.2 Communication Protocol .....	12
2.2.2.1 Modulation .....	12
2.2.2.2 Backscatter.....	13
2.3 RF Inductors .....	13
2.4 RFID Antennas.....	14
2.5 Reader Chip.....	15
2.6 Microcontrollers .....	17
2.7 Crystal Oscillators.....	19
2.8 Wireless Communication Devices.....	21
2.6.1 CC2530 .....	21
2.6.2 Xbee Pro.....	21
2.9 Battery Types .....	23
2.10 Battery Charging .....	25
3.0 Design.....	27
3.1 Tags .....	27
3.2 Reader Unit .....	28
3.2.1 Power .....	28

3.2.2 LED Indicators .....	31
3.2.3 RFID Reader IC.....	34
3.2.4 Enclosure.....	49
3.3 Microcontroller Design .....	52
3.3.1 Microcontroller Hardware .....	52
3.3.2 Microcontroller Software.....	53
3.4 Xbee Wireless Communication.....	55
3.4.1 Breakout Board .....	55
3.4.2 RS-232 to USB Conversion .....	57
3.4.3 Xbee to Microcontroller Communication .....	57
3.5 GUI .....	58
3.5.1 Tag Class.....	59
3.5.2 Map Class .....	60
3.5.4 Radio Class .....	60
3.5.5 Taghit Class .....	61
3.5.6 Location Class.....	61
3.5.7 Calc Class.....	62
3.5.8 Reader Class.....	63
3.5.9 GUI Class .....	63
3.6 PCB Layout and Design .....	65
4.0 Design Summary .....	68
4.1 Hardware Design Summary .....	68
4.1.1 Power and Indicators .....	69
4.1.2 Reader .....	69
4.2 Software Design Summary.....	70
4.2.1 GUI .....	70
4.2.2 Microcontroller .....	71
5.0 Prototyping and Testing.....	72
5.1 Prototyping .....	72
5.2 Building .....	73
5.3 Testing.....	73
5.3.1 Tags .....	73

5.3.2 Battery and Power .....	75
5.3.3 Reader Microcontroller.....	76
5.3.4 Xbee Communication.....	78
5.3.5 GUI .....	81
5.3.6 Completed Reader .....	87
6.0 Administration .....	87
6.1 Milestone Discussion .....	87
6.2 Budget and Finance .....	89
7.0 Project Summary.....	91
Appendix .....	a
Table Of Figures .....	a
References .....	c
Copyright Permissions .....	d

# Executive Summary

The senior design project that we designed could best be described as a mobile tracking system. The system will contain a small portable reader that the tracking target will wear. Most forms of RFID systems on the market apply tags to objects they want to track and place the reader at a designated point. In this type of system the exact location isn't practical, but just a general location. Companies using this design might simply want to know if a particular good with a tag attached has entered or left a warehouse. In another application, a manager may want to know how many parts are going through a node in an assembly plant. Our project takes the opposite approach. Rather than have the tags on the object to be tracked, the reader is placed there. The tags are instead laid out in a grid and location is determined by tags the reader is hitting. The reader will be equipped with wireless technology that will allow it to communicate to a base station. The base station will simply be a computer with software tailored to the end users needs. The graphical user interface will allow the real time tracking of the reader and show its location on a map.

The standard system for tracking goods using RFID could be expanded to mimic ours by using a large number of readers, but the cost associated with this wouldn't be practical for most applications. The final placement of tags using our system can be adapted for a variety of uses by creative manufacturers. One example would be to imbed the tags into flooring prior to installing it. Another would be to place them in ceiling tiles or wall fixtures. The system can be tailored to the particular needs of the user. The more tags that are placed in the environment the better the resolution.

As we developed the project, one of our main focuses was cost. While this was a practical issue to college students without funding, it has enabled us to produce a product that has some additional benefits. The tags that we use are all passive and don't have the same maintenance issues that are required for active tags. This is a vital requirement for a grid that will be laid out in a permanent fashion. Placing the grid in flooring would require pulling it up to charge dead tags. In addition, since the system doesn't limit the amount of tags you can place in a grid, increasing the density to account for random failures will allow the system to last longer before any major maintenance is needed.

# 1.0 Project Description

This section will explain the reasons and motivations for the design and implementation of this RFID tracking system. It will explain the desired goals and objectives of the designers. This section will also provide, in detail, the specifications of each component that comprises this system.

## 1.1 Motivation

Automatically tracking the location of objects and individuals has been a desired and practical objective for many years. It has application in the military, corporate, commercial, and private sectors. GPS has revolutionized all outdoor location-based services, yet there is still no actual standard for technology used in precision indoor tracking. Indoor position-based systems have been slow to take off for a number of reasons, including high cost, design complexity, and limited accuracy. GPS-like technologies for indoor-based location tracking still lack positioning accuracy, and cost-effective alternatives must be considered. Available alternatives include Bluetooth, wireless LAN, and RFID.

This project focuses on the design and implementation of using RFID technology to track the location of personnel and visitors in a cooperate setting. There are many driving motivations to finding an accurate, low cost and easy to use indoor position tracker. Many companies have employees with varying levels of security access within a single building, and may want to monitor and regulate the location of all personnel for security purposes. They may have visitors come into their facility and need a way to insure safety and security by knowing their location and when they have reached a restricted area. Other companies may want to track personnel productivity by being able to easily know how many times and how long an individual may spend at the company water cooler. Child care facilities need a fast and easy way to keep track of the safety and location of each child under care. Radio frequency identification has proven to be effective in much industry application thus far. We believe that RFID also provides a great solution to effective and accurate indoor location tracking.

The idea that RFID is a great solution for position tracking is not; however, a widely accepted point of view within the wireless communication industry. Many believe that RFID is simply not a practical solution for this type of application. Reasons for this point of view include limitations on range, high signal noise, sensitivity to environment, and high cost implementation. The designers of this system are motivated to overcome these challenges in order to reach a smart design that is both effective and low cost.

## 1.2 Goals and Objectives

The goal of this project is to develop a location-based tracking system using RFID technology. The design must be accurate, easy to set-up, adaptable to a wide range of indoor environments and reliable. A successful design will be demonstrated by viewing the real-time location of a portable RFID reader unit. The reader location will be viewed on a computer screen with a background representing a scaled layout of the floor plan in which the object is to be tracked. The graphical interface will use an indicator mark to identify each unique reader on the screen. The indicator will move relative to the actual motion of the reader unit. This will allow the user to easily keep track of any individual who is carrying a reader unit while in the building. The following is a list of high level objectives to be met by this design.

- Reliable operation
- Accurate to at least 1 square meter
- Low cost design
- User-friendly interface

## 1.3 Requirements and Specifications

This section will explain the minimum requirements to implement this design. Requirements will for each major component and the corresponding specification will be presented.

### 1.3.1 Tag (ALN-9640)

The tags used in this design must be passive and operate in the UHF frequency band. They must have minimal directional sensitivity. A mesh network of evenly spaced tags will be distributed along the floor of each room that tracking is desired. The dimensions must be small enough to be placed on the floor without impeding walking traffic. The tags must be able to with stand the pressure of a 150 lb person walking on top to the tags. This is a modest amount of pressure and is only required for the prototype. The end product will need to withstand a much greater amount of weight and would be handled by farther packaging and installation designs. Figure 1 shows a summary of the minimum specifications required form the ALN-9640.

No.	Requirement	Specification
1	Flat enough to place on flooring and remain unobtrusive	0.05mm over antenna 0.25mm over chip
2	Operate in UHF frequency band	840MHz to 960MHz
3	EPC Gen 2 and ISO 18000-6C compliant	Yes
4	Must have at least 8-bit TID	32-bit TID
5	Must be pre-programmed with unique ID	Pre-programmed with unalterable 64-bit UTID
6	Must be able to withstand being walked-on	5 N/mm <sup>2</sup> or less
7	Moisture resistance	Up to 90%non-condensing

Figure 1 - ALN-9640 Requirements and Specification

### 1.3.2 Reader Unit

The reader unit in this design must be light weight and easy to carry. The maximum amount of weigh tolerated in the reader unit is 2.0 lbs. The dimensions of the case must be within 6x6x1 inches. A size any larger than this is considered to be a burden to carry. It is intended that the reader unit be no more obtrusive than a bulky portable calculator.

In addition to the portability of the device, the reader must be accurate. The reader must be able to detect tag ID at an absolute minimum distance of 1 meter. The minimum accuracy required for this system is therefore 1 meter. This is a safe requirement and is used as a baseline for accuracy. The absolute minimum charge life required from the battery is 3 hours. For the end product, it is desired to have a device that will stay powered throughout a typical 8 hour work day, but charge requirements will be kept modest for the prototype. Figure 2 summarizes the requirements for the reader unit and provides the specifications of individual components.

No.	Requirement	Specification
1	Must be small size	5.12 x 2.56 x 0.97 (in)
2	Must be light weight	Estimated 1.2 lb max
3	1m read range	Yes
4	1m <sup>2</sup> accuracy	Yes
5	UHF frequency range	840MHz to 960MHz
6	EPC Gen 2 ISO 18000-6C compliant	Yes

Figure 2 - Reader Unit Requirements and Specifications



## 2.0 Research

### 2.1 RFID Technology Overview

RFID or radio-frequency identification is a technology that has been around for some time and has a wide range of useful applications. RFID uses radio waves to communicate between a transponder, or tag, and reader to achieve the results that the user desires. RFID has been used in some industries for a while and is just being discussed in others. An RFID system, simple or complex, is composed of two primary parts, a reader, and a tag. The tag is usually attached to the object you wish to track or keep track of. The reader is the device that can be either portable or not, that uses radio waves to locate when a tag is nearby and then read the information stored on the tag. Shown in figure 3 is the overall view of an RFID system.

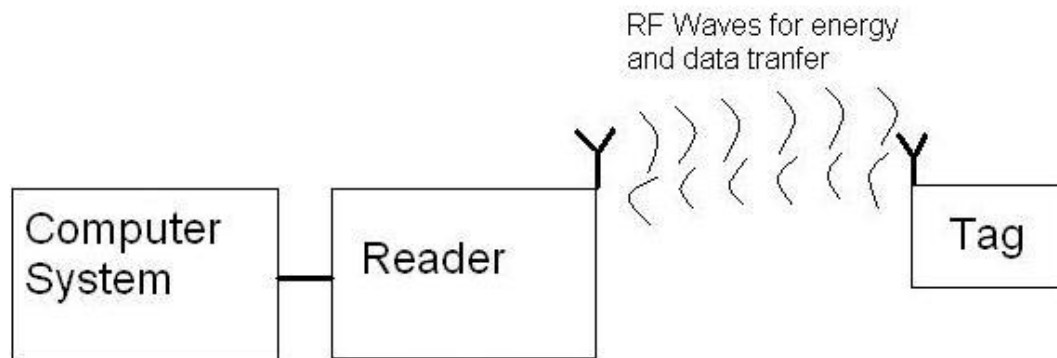

Figure 3 - RFID System Basics

#### 2.1.1 RFID Applications

RFID technology is all around us and many people don't even know it's there. Some of the older uses of RFID are for livestock identification. Livestock is tagged, usually in the ear, so that it can be identified quickly and efficiently. One area that probably everyone has had experience with RFID is in merchandise control. When you walk out of a store and bells and whistles go off, accusing you of shoplifting, you have RFID to thank for that. Everything from libraries to department stores use this technology to help prevent their merchandise from walking out the door without being paid for. Another application that many people have firsthand experience with is contactless cards that act as keys. Many buildings have implemented RFID access systems to open doors and grant admission to certain areas for authorized individuals. This contactless card

technology is even being implemented into bank cards so one can quickly pay for things. When you move up in size and complexity of the system the possibilities are endless. It is now common to have an RFID tag in your automobile that allows you to pay tolls on roadways without even slowing down. Similar technology is also being used in warehouses and shipyards to track and monitor large pallets and even shipping containers.

All of the applications for RFID listed above have been pretty well accepted by society and haven't caused much of a ruckus, but one of the proposed new applications might not be so lucky. Barcode technology is starting to be considered by many as "outdated". While many of the uses for RFID to replace barcode technology, none would have as much of an impact as replacing UPC barcodes on merchandise. Everyone is used to seeing a UPC or universal product code on pretty much everything they buy. Using RFID could have an immense impact on how we shop at the grocery store. It is possible to have RFID tags on everything we buy. A trip to the grocery store could include simply placing everything you wish to purchase into your shopping cart and walking out the door. In the amount of time it takes you to walk out the door an RFID reader would read all of the tags from the products in your cart and then read the tag embedded in your bank card to charge you for the purchase.

## 2.1.2 Frequency

One very important detail about an RFID system is the radio frequency that is used. The frequency plays a big role in the specifications and characteristics of the entire system. Most RFID systems fall into one of three main categories of radio frequency. The first is LF or low frequency and usually ranges between 125 and 135 kHz. The second is known as HF or high frequency and is usually operated at 13.56 MHz. The last is UHF or ultra high frequency and is mainly found in the 850-960 MHz range, but there are systems that go up into the 2.4 GHz and above. The frequency used will most likely be one of the first considerations being made before the design of the system is started. As you have seen from section 2.1.1, there are many applications for this technology. Each of the three main frequencies has its own pros and cons which all need to be considered before making a decision.

### 2.1.2.1 Range

Read range is most likely the first consideration one will have when thinking about an RFID system. Each frequency has its own limitations on range which can be seen in figure 4.

Frequency	LF 125-134 KHz	HF 13.56 MHz	UHF 860-960
Read Range	Up to 2m	Less than 1m	Can be greater than 3m

Figure 4 - RFID tag range based on frequency

### 2.1.2.2 Power Source

The radio frequency used determines the way in which power will be received by the tag. For both LF and HF frequencies, inductive or magnetic coupling is what provides the power to the tags. For UHF and above, capacitive or electric coupling provides the power to the tags. Due to the nature of inductive coupling, tags must be fairly close to the reader to receive the power required for operation. This fact has a direct correlation to the tags read range which has already been seen in section 2.1.2.1.

First we will take a look at inductive or magnetic coupling. The relation between the reader and transponder, or tag, is similar to a transformer. The alternating magnetic field radiating from the antenna of the reader interacts with the antenna on the tag and a voltage is generated on the tags antenna through inductance. This voltage is then used to power the tags IC. The efficiency of this power transfer relies on a number of variables including frequency, the number of windings in the antenna, the area enclosed by the coil, and the orientation and distance between the two antennas. The number of windings becomes less important as frequency increases as can be seen in the different number of windings between LF and HF antenna. A LF or low frequency antenna can have anywhere between 100 and 1000 windings while a HF or high frequency antenna can have as little as 3 windings.

The second kind of coupling for passive tags is capacitive or electric coupling. This type of coupling is found in the UHF range and above. This type of coupling is what allows passive RFID tags to have read ranges in the 3 to 5 meter range. These systems utilized tag ICs that require very little power. These systems use backscattering to get the signal back to the reader so the amount of power the IC needs is minuscule and can be rectified into DC from the received radio energy.

### 2.1.2.3 Additional Frequency Characteristics

There are a lot more characteristics that depend on the radio frequency used. If read range is not your only or primary concern when designing an RFID system, it might be difficult to choose a specific frequency. The object that you need to track will most likely play a big role in your frequency decision. When looking at figure 5 you can see some of the additional characteristics that are dependent on the frequency. If you only need to track a small number of objects and the objects might be around or even under water, you definitely would not want to use a UHF RFID system because the frequency of those radio waves have a

difficult time penetrating water. You might think why you would care about the characteristics pertaining to water, but when it comes to tracking living organisms you must take into account how much water content is in the organism and if it would affect your system. Using the information from the same table it can be seen that if you need to read a large number of tags at one time, perhaps like the example given earlier about a grocery store, you would most likely be better off using something in the UHF frequency range.

Frequency	LF (125-134 KHz)	HF (13.56 MHz)	UHF (860-960 MHz)
Data Rate	Slow	Faster	Fastest
Multiple tag reading ability	Poor	Fair	Good
Affected by water	No	Somewhat	Yes
Metal Penetration	Fair	Poor	Poor

Figure 5 - Additional characteristics affected by frequency

## 2.2 Tags

RFID tags range in size and complexity from a small sticker to a book sized transmitter complete with battery and circuit board. The first thing to look at is the different type of tags. There are three main types of tags, passive, semi-passive, and active. A passive tag uses no battery and receives all the power it needs to transmit, from the reader. The read ranges listed in section 2.1.2.1 are all for passive tags because as soon as you add a power source to the tag, range can dramatically change. A semi-passive tag incorporates a battery but only transmits when it is in the presence of an RFID reader. The last type of tag is an active tag which also has a battery, but unlike the semi-passive, an active tag is always broadcasting its signal. Active tags are normally only found in the UHF or microwave frequency ranges.

### 2.2.1 Passive UHF Tags

Passive UHF tags, like most RFID tags, come in a variety of shapes and sizes. There are tags for everything from the windshield of a car to an ear tag for an animal. You can even purchase just the tag inlay on a paper medium so that any type of housing you require can be built around it. All passive UHF tags have two main components required for operation, an antenna, and an IC chip.

There are many different companies that produce RFID tags and they of course come in many different quantities. Most companies offer a sample pack of tags ranging between 50 and a hundred tags, while other companies don't sell any in quantities less than 5,000. For this project, between 50 and 100 tags will be plenty sufficient for what we need.

### 2.2.1.1 Tag Antenna

The design and implementation of antennas for RFID tags is actually a complex subject. Different tag manufactures have radically different designs for their antennas leading to slightly different read characteristics for each tag. The first, and probably most important function of the antenna, is to absorb the RF waves given from the reader in order to power the IC chip on the tag. The tag antenna can also play a part on what type of object you want to attach the tag to. Certain antennas can react negatively when attached to some materials such as glass.

Most of the antennas shown in figure 6 are of the half-wave dipole variety. For a frequency of 900 MHz the half-wave dipole should be 16 cm long. The antennas we saw before are definitely not 16 cm long. The solution to this is to take a longer antenna, such as 16 cm, and squeeze the ends of it until you get an antenna with a smaller area. The antenna is now the same length but takes up less space, but this does come with some downsides. With all of the parts of the antenna that radiate away in one direction, the energy makes it away from the antenna. When you take parts of the antenna where there has been a twist or change in direction, the parts of the antenna that are next to each other but with opposite current flow, can nearly cancel each other out and not radiate any energy from the antenna. A twisted antenna also has different inductance and capacitance of a straight antenna with the same length. The magnetic potential along the wire is different because of the parts of the antenna that are next to each other with opposite current as described before. With these changes, the resonant frequency of the wire is changed which in the twisted antenna case, the frequency is increased. The frequency is increased compared to a straight antenna with the same length. This means that instead of the twisted antenna being the same length, it actually needs to be slightly longer to make sure it has the correct resonant frequency.

Once an acceptable length has been determined for the antenna, you must then consider the impedance matching with the IC. There are ways of adding components within the antenna structure to match the IC such as shunt and series inductors. Looking at figure 6 once more, you can see a shunt inductor being used in the first tag in the top left of the figure. The shunt inductor is the large loop that can be seen in the center of the tag. The tag, made by Texas Instruments, uses the inductor to make sure that the tags inductance is matched with the IC and the whole package can fit within a small foot print of only 9 cm.

### 2.2.1.2 Tag IC

The tag IC has many obstacles to overcome and an RFID tag would be nothing without it. The IC's main purpose is to modulate the received RF signal, which we will discuss later on. This leads to the first task for the IC, drawing enough power from the electromagnetic waves received to power it. Most tag ICs require between 10 and 30  $\mu\text{W}$  to operate. Although the IC doesn't require a lot of power, there is also not a lot being received from the RF waves. The IC needs to use a rectifier to take the alternating RF and turn it into DC that the chip can use. A charge pump can then be used in order to amplify the voltage to the higher amounts needed to power the IC. To get even more voltage, more charge pump stages can be added but there needs to be a balance because with an increase in stages, comes a decrease in efficiency. Once the IC has the proper amount of power, it can use logic circuitry to do the actual modulation on the signal.

The tag ICs used in RFID tags are very small. The tag IC is normally as small as 1 mm X 1mm. After the IC is manufactured it is usually attached to what is known as a strap. The strap is made from a conductive material and allows for easier attachment to the antenna. Once the IC and antenna have been joined, the result is known as a tag inlay, which can then be attached to something else or encased in plastic to create a rugged RFID tag.

### 2.2.1.3 Passive Tag Resonators

A passive tag's ability to efficiently draw energy from the reader field is based on the electrical resonance effect. The coupling or antenna element of the tag is an inductor coil and capacitor connected together and designed to resonate at a desired frequency. This design will use tags that are calibrated to resonate at 915MHz. Figure 6 shows a simplified schematic of a UHF tag resonator.

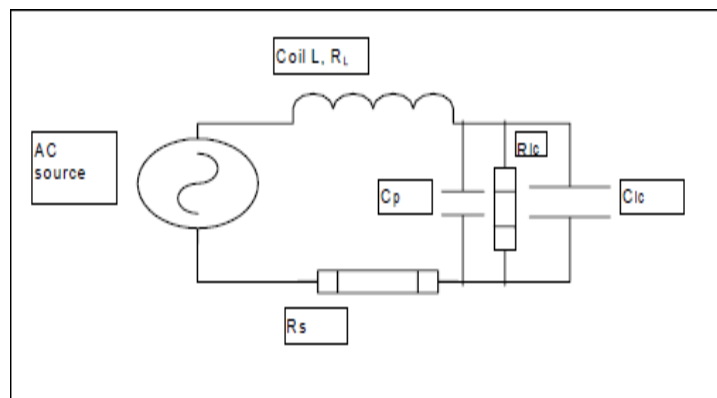

Figure 6 - Tag resonator

The tags resonate frequency is determined by choosing the inductive and equivalent capacitive values to satisfy equation (1)

$$F_{\text{res}} = 1 / [2\pi\sqrt{LC}] \quad (1)$$

This equation shows that when a tuned circuit is resonating, the sum of its capacitive and inductive reactance is zero. In this situation, the impedance is minimized and the circulating RF current flow in the circuit is desirably maximized for best sensitivity (Geick, S21).

The quality factor (Q) of the coupling element defines how well the resonating circuit absorbs power over its relatively narrow resonance band. In smart label RFID applications, the Q value demanded is reasonably high (Geick, 271). Since most of the resonant circuit's tuning capacitance is located within the IC microchip were high capacitor Q can be realized, the effective circuit Q value is determined mainly by the antenna coil losses. The coil Q is usually calculated according to equation 2 (Geick, 271).

$$Q = \omega L / R_s \quad (2)$$

Where  $R_s$  is the coil's total effective series loss resistance taking into account both the DC resistance and the ac resistance due to high frequency current flow concentration caused by skin-effect phenomena in the conductor winding.

Practical passive tag systems usually operate with a coupling element resonator Q within the range of 30 to 80. Higher Q values than this are generally not feasible because the information bearing amplitude modulated reply sidebands are undesirably attenuated by the resonator's bandpass frequency response characteristic (Geick, 279).

The transfer of energy and data in passive tag applications is based on vicinity inductive coupling. In near-field inductive coupling, the reader antenna loop and the tag coil windings establish a loosely connected 'space transformer' resulting in power transfer across short bidirectional reading distances that are comparable to the actual physical dimensions of the field creation or transmitting antenna loop. Such coupling is deemed to be predominately magnetic if the physical dimensions of the transmitting loop are small compared to the system's operating wavelength. Magnetic flux linkage and energy exchange offers between the two resonant coil windings having the small coefficient of coupling between them. The UHF magnetic field is generated by the reader antenna from its connection to the RF power source of the reader. The chosen AC current frequency determines the operating frequency of the reader system. (Geick, 281)

## 2.2.2 Communication Protocol

The International Organization for Standardization has published many standards for the operation of RFID technology. Since our project focuses mostly on the use of UHF the standardization we will be utilizing is ISO 18000-6. The ISO specifies pretty much the complete operation of the system. It describes the physical interaction between the tags and interrogator, their operating procedures and commands, and a scheme to manage collisions between tags when there are multiple tags in the read area.

Within the ISO 18000 standardization, there is also an EPCGlobal specification dealing with RFID systems. For our project we will be using the EPC Class-1 Generation-2 UHF RFID communication protocols. The specification defines the requirements for the passive-backscatter system which we will discuss in section 2.2.2.2. The specification also describes the ITF protocol to be used which is Interrogator-talks-first, which simply states that the reader, or interrogator, will talk first while the tag simply listens. It also states that the interrogator and the tags are not required to talk at the same time. It states that the communications can be half-duplex which means ones talks while the other listens and vice versa. The specifications also go into detail on what type of modulation the system should use. The specifications state that the reader, or interrogator, should communicate using DSB-ASK, SSB-ASK, or PR-ASK modulation and that tags should be able to demodulate all three of these types.

### 2.2.2.1 Modulation

Since RFID uses radio waves, there must be some type of modulation scheme in order for information to be passed from reader to tag and vice versa. There are three different types of modulation used in radio systems, amplitude modulation, frequency modulation, and phase modulation. This is because the amplitude, frequency, and phase are the three main characteristics of an electromagnetic wave and given a continuous wave sinusoidal for example, can be modified in order to pass information. For RFID systems there are a few different modulation schemes that are used. ASK or amplitude shift keying, FSK or frequency shift keying, and PSK or phase shift keying are the digital modulation schemes used for RFID.

When reviewing the specification listed above, ASK is the modulation type that it states should be used. ASK is similar in some regards to AM modulation but ASK is a digital modulation while AM is analog. ASK modulation is very simple to understand and use. The main premise behind ASK modulation is also known as OOK or on-off key modulation. This modulation is easily understood from the name, the signal is simply turned off and on. This works well for RFID applications since using this modulation allows for easy communication of binary data. The ISO-18000 specifications say that the modulation used should be ASK and it can be double sideband, single sideband, or phase reversal.



## 2.2.2.2 Backscatter

As we already discussed there are only two parts to an RFID tag, an antenna and an IC chip. For passive tags there is no power source so passive tags don't have any radio transmitter. Instead the tags modulate the power from the antenna and that is reflected back to the reader. Objects that around half the wavelength of an electromagnetic wave will tend to reflect the wave. The tag antennas of course are specifically designed to maximize the ability to reflect a wave at the frequency being applied to it.

If a tag simply reflected the wave, the identification portion of RFID would be non-existent. The tag needs to reflect an electromagnetic wave that has been modulated by the IC chip attached to the antenna. To understand the basics of how this can be done, it is easier to look at two different circuits. The first is an antenna with an open circuit to ground, and the second is with a short between the antenna and ground. If we look at the short circuit example, we can say that a current will be induced on the antenna. If there is a small load, or a short circuit in this example, the wave will make it back to the antenna where a voltage will be induced, generating a backscattered signal that will be sent back to the reader. Now we will look at the second circuit example, a high impedance load, or an open circuit. Unlike the previous example, with this circuit no current will be induced so there will be no voltage making it back to the antenna, and no backscattered signal. If you now insert a transistor into the open circuit example you have the basic operation of an RFID tag. By putting a transistor between the antenna and ground you can turn on and off the transistor which will of course turn on and off the backscatter signal from the tag. This is the fundamental operation behind the OOK modulation.

For the backscatter scheme to work, the reader must be transmitting a signal. There are two main types of communication schemes in radio systems, half-duplex and full-duplex. In half-duplex only one party talks at a time, that is when you transmit you are not listening. In full-duplex, you are listening, or receiving, simultaneously while you are talking, or transmitting. For a passive RFID system, full-duplex communication needs to be used since the tags are backscattering the signal from the reader. The receiver or reader is designed to constantly transmit while listening specifically for the modulated backscattered signals.

## 2.3 RF Inductors

Typically, in RFID, GPS, mobile phone, radar, satellite radio, and Wi-Fi applications that use high frequency analog circuits and signal processing, the inductance is one of the most important components. Usually, it can take on some of the main features including circuit tuning, impedance matching, high-pass and low-pass filters, and can also be used as RF chokes. When considering inductor performance, the Q value is the most important measure. Inductor Q value is a measure of performance indicators, it is a dimensionless parameter

used to compare the oscillation frequency and the energy loss rate (Matthys, 221). The higher the Q value, the closer the performance of the inductor is to an ideal lossless inductor. A high Q contributes to lower energy loss and lower power consumption. This is important to our design in order to have as little battery drain as possible.

In addition to the Q factor, inductance is an obvious characteristic to consider when selecting an inductor. For high frequency applications, a relatively small inductance is required. Typical values are in the micro to nano (Henry) range. Inductance value depends on several factors, including the structure, core size, core material and the actual number of turns in the coil. In addition to inductance, DC resistance, current, and self-resonate frequency (SRF) are also important parameters to consider when selecting the appropriate inductor. High frequency devices typically use hollow or inert ceramic cores (Matthys, 222). They provide a big ferrite core inductor value.

## 2.4 RFID Antennas

Because antenna design can be a project of its own, this section will investigate some of the antenna designs typically used in RFID applications. The designers of this project will not be designing the antenna itself. The research presented in this section provides a foundation to the task of selecting the appropriate antenna to meet the desired specifications. Research has shown that there are three different types of antenna designs that are commonly used.

- **Linear Polarization** (dipole antennas): The electromagnetic wave propagates entirely in one plane, either vertical or horizontal, in the direction of the signal propagation. This is the best wave propagation when the tag orientation is known. To obtain the best read rates, the RFID antenna and RFID tag should be matched in polarization.
- **Circular Polarization:** These antennas are also known as helix, crossed dipoles and patch. With this type of design, the electromagnetic wave propagates in two planes creating a circular effect making one complete revolution in a single period. Since the RFID antenna continuously emits a wavelength, the rotational field will eventually cover any tag that is in its path. The propagation path is similar to a corkscrew shape. This type of design is best when the orientation of the tag is unknown. The down-side to this design, when compared to the linear polarized dipole, is that you inherently lose at least 3 dB of signal strength.
- **Monostatic Circular or Bistatic Circular:** Mono static seems to be the most common RFID antenna used. It uses a single common port to transmit and receive signal. The bistatic uses 2 RFID antennas in the same physical housing and uses one port to transmit and the other port to receive. It is common for monostatic reader to have a listen before talk port. This type of communication will not be needed in this design.

## 2.5 Reader Chip

The heart of this project is the RFID technology so the reader chip decision is of high importance. There are several manufactures of IC chips that are complete RFID readers. These chips already have all of the required components needed for signal modulation, demodulation, amplification, and even voltage regulated supplies for connection to an external MCU.

Impinj is a company that manufactures many different things for RFID systems, from reader chips to antennas. Their Indy line of reader chips is actually built off of technology they acquired from Intel. The Indy line consists of three different chips, a R500, R1000, and R2000 chip. Out of the three chips, the R1000 and R2000 would best suit our needs for the project.

The R1000, like all of the Indy chips, use the EPCGlobal UHF Class 1 Gen 2/ISO 18000-6C air interface protocol. The R1000 can operate in DSB, SSB, or PR-ASK modulation modes. The R1000 can operate in the dense reader mode which is designed for situations where more than would RFID reader would be present in the area. The chip has a configurable internal amplifier and has support for an external amplifier if needed. Although it does not affect us much, the chip is capable of any worldwide accepted frequency for UHF RFID which is 840-960 MHz. In the regular listen before talk mode the chip is capable of a sensitivity of -110 dBm and in the dense reader mode it is capable of a sensitivity of -95 dBm. The chip comes in a 56 pin QFN package that would work well for us to surface mount to our printed circuit board.

The second RFID reader chip that Impinj produces that might work well for our project is the R2000. The R2000 has all of the same features as the R1000 and then a few additional features. The internal amplifier on the R2000 is configurable up to 17 dBm and the chip still supports an external amplifier. The transmit power for the R2000 is also configurable up to greater than 25dB. The R2000 has the same sensitivity and frequency specification as the R1000 but has more features when it comes to power. The R2000 has a low power mode where the chip is only drawing 200  $\mu$ W in standby. When comparing the R1000 and R2000, the R2000 chip would be our choice because of some of the additional features not found on the R1000. The low power mode is a big plus since our unit will be portable and run off of a battery.

The Impinj Indy reader chips really seemed like a good choice for our project. Unfortunately there was one pretty big problem and this was availability. During initial research many emails were sent to the company about acquiring a small number of chips for our project. The company replied with distributor contacts who then directed us elsewhere and the whole process left us in an endless loop. Due to the fact that we could not find a way to actually purchase any of these chips, we had to abandon the idea of using them.

Another company that manufactures RFID reader chips is a company called Austriamicrosystems. The company manufactures three different reader chips

with slightly different specifications. The three chips are the AS3990, AS3991, and AS3992. The AS3991 and AS3992 both have potential to be used for our project.

The AS3991 is the first reader chip to consider from austriamicrosystems. Like the Indy chips from Impinj, the AS series chips contain all of the hardware for the RF transceiver and protocols needed to read UHF RFID tags. One nice feature about these chips is the connections for an external MCU. The AS3991 has an 8-bit parallel or 4-bit serial interface to an external MCU. The chip also provides regulated voltage to the MCU between 1.8 and 5.5 volts. Like the Indy chip, the AS3991 is capable of ASK and PR-ASK modulation yet the AS3991 has an adjustable ASK modulation index. Again like the Indy, the AS3991 is capable of any frequency that is used for UHF RFID, 840-960 MHz. This chip's internal power amplifier can generate an output power of 20 dBm. The chip has a sensitivity of -66 dBm and has several different power modes including a low power standby mode. The AS3991 comes in a QFN package with 64 pins and is 9mm by 9mm. The AS3991 can be found on both digikey.com and Newark.com. On digikey.com the chip is \$74.10 yet on newark.com the chip can be found for only \$60.31. On the austriamicrosystems website the chip is shown at the 1K price of \$36.89, but when you try to order just one the price goes to around \$120, so Newark.com would be the best place to purchase the chip.

The AS3992 is a slightly upgraded version of the AS3991. One of the first characteristics that are improved from the AS3991 is the increased sensitivity to -86 dBm. Another added feature of the AS3992 is on chip pre-distortion which allows for a more efficient external power amplifier. Other than a few other small changes the AS3992 is identical to the AS3991. The AS3992 still has all of the needed components for external MCU communication and power, is capable of the same RF modulation, and comes in the same 64 pin QFN package. The AS3992 chip can be found on digikey.com for \$83.49, while Newark.com has the chip but it only sells it in quantities of 50 or greater, which is beyond what we need.

The last thing we considered for the RFID portion of the project is not a single chip but rather 2 separate chips. The Impinj and austriamicrosystems chips contain both transceiver and decoder hardware but we could purchase these two components separately and combine them ourselves. We would need to simply purchase a transceiver capable of 900 MHz frequencies and a decoder that is ISO-18000 and EPC gen 2 compliant.

The first component is the RF transceiver. After doing some searching on digikey.com a 915 MHz RF transceiver made by Atmel, the ATA5429, was found. The chip is capable of only 5 dBm of output but has a sensitivity of -112.5 dBm. The chip comes in a few different packages but the 48 pin QFN would be most preferred. The chip sells from digikey.com for only \$3.97, which is already looking much better than the austriamicrosystems chip.

The second thing that needs to be considered for this 2 chip design is a decoder chip. A company called EM Microelectronic sells a chip called EM4298. The chip contains an encoder/decoder circuit for UHF and is ISO-18000 and EPC gen 2 compliant. The chip simply needs two things to operate effectively. It needs an RF front end, which we already looked at one from Atmel, and a microcontroller which we would need with the austriamicrosystems or Impinj chips anyway. The data sheet lists the chip as low cost but since no prices were listed, the company was emailed. The chip cost varies with the quantity ordered but for a smaller quantity the chip costs around \$10.

When comparing all of the different options for the RFID component of our project, the austriamicrosystems AS3992 reader chip appears to be the best option. The chip is a little expensive but it is readily available from reputable sources. The chip has good sensitivity and “plays nicely” with microcontrollers. The chip's power requirements are reasonable and allow for the chip to be used in a mobile device where a battery will be needed.

## 2.6 Microcontrollers

One microcontroller will be needed for our mobile reader in our project. This microcontroller will need digital input pins to receive data from the RFID chip and digital output pins for communication with the Wi-fi module. The microcontroller will ideally have a serial output buffer for the digital output pins to make this process a bit easier. In addition, the power usage should be low since it will be utilized as a mobile device and battery length is a concern. The final concern will be size. Since the reader unit is intended to be as unobtrusive as possible, size will be an important consideration.

The first microcontroller that we looked at was the Atmega328. The Atmega328 has 6 analog inputs and 14 digital input/output pins which fits our needs for this project. The chip needs a 5V power supply so this may be a concern depending on the battery setup and expected time it will need to run before needing to be recharged, but it's still within the specifications that have. Size is a consideration in our project as well. The size of the IC is shown in figure 7 below for reference.

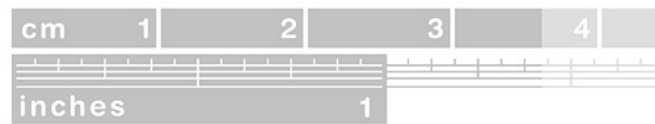
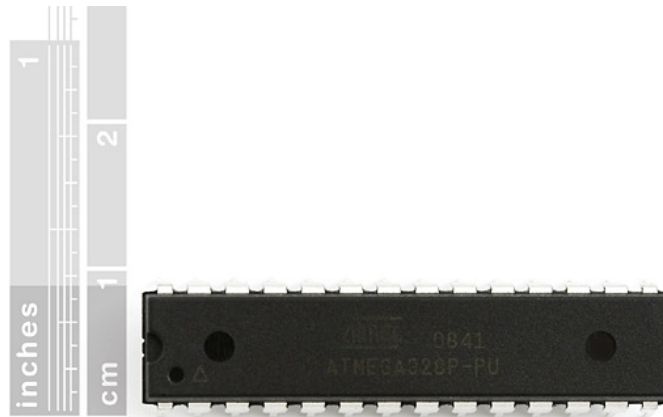

Figure 7 – Size comparison of the Atmega328 (Reprinted with permission from sparkfun.com)

This particular chip is popular among hobbyists due to the open source board known as the Arduino. The Arduino is intended mainly as a prototyping board, but its ease of use has opened up embedded programming to a wider audience. The open source nature of the product has brought a large number of code libraries that may make some elements of programming a bit easier – or at least less tedious. In addition, the Arduino itself can be used to program the chip without the need to purchase a standalone board. This may seem like a minor issue, but it should still be considered when comparing the two products.

The second microcontroller that we looked at was the MSP430 from TI. The chip has 8 analog input and 10 digital input pins, although some of these share the same pin location and cannot be used for both at the same time. The sharing of pins won't be an issue for us since it still has more that we need. The chip itself is designed to be a low power device and would work well at 3.3V, which is a nice benefit of using this product. This IC is a little smaller than the Atmega328, having only 14 pins in total. Like the previous chip, the size may or may not end up being an issue, but there is no downside to have a small chip and it allows us to construct a smaller overall reader.

The programming of the MSP430 can be done through a board provided from TI. While the popularity of the MSP430 in the hobbyist community isn't as large as the Atmega328, TI has a wide range of coding libraries for use in this project.

The final decision on which chip to use comes down to a better selection of code libraries but higher power consumption for the Atmega328 vs. a smaller amount of libraries and lower power consumption for the MSP430. The MSP430 is quite a bit faster than the Atmega328; however, both would work well for our needs. The cost for either of the microcontrollers was very reasonable, so it wasn't a consideration. After weighing the advantages and disadvantages of both, we ended up deciding on the MSP430. The following figure 8 shows the general specs we looked at.

	MSP430	Atmega
Voltage	3.3 V	5V
Architecture	16 Bit	16 Bit
Clock	16 MHz	8 MHz
Digital Pins	10	14
Analog Pins	8	6

Figure 8 - Comparison table for the microcontrollers

## 2.7 Crystal Oscillators

Oscillators are made up of an amplifier and feedback network that selects a portion of the amplifier output and returns it to the amplifier input. The oscillator circuit is dependent on two key conditions. First, the loop gain needs to be greater than the losses around the oscillator loop or at least equal to 1 (Neamen, 1074). Second, the loop phase shift must be equal to  $N \times 360^\circ$ , where  $N = 0, 1, 2, \dots$  (Neamen, 1075). The loop phase angle shifts determine the frequency at which the oscillator will operate. A change in the net loop phase angle results in a change in output frequency of the oscillator circuit. In order to minimize the net phase shift, a quartz crystal is placed in the feedback loop. Because of the changes in impedance of the quartz crystal due to changes in applied frequency, all other components of the circuit should be considered constant reactance resulting in an adjustment of the quartz crystal frequency to a reactance that satisfies the loop phase characteristics.

When the group selects an oscillator to use in this design certain conditions and parameters will be considered before making a selection. Using these considerations should insure that the correct, best suited oscillator is selected. The crystal oscillator selected will have common characteristics that are common to industry standards. These characteristics include standards in available frequencies, drive currents, capacitance, pin outs, etc. However, the following key electrical parameters of the crystal oscillator must be selected by the group.

- **Package:** The most common industry wide standard package for a crystal oscillator through hole device is a 4-pin dip half size (Matthys, 102). The most common package for an surface mount device is the 5x7 mm ceramic 4 pad device (Matthys, 102).
- **Frequency:** The reference frequency needed will depend on the chip selected for the design. The AS3992 IC from Austria Microsystems requires a reference frequency of 20MHz. This is standard for RF applications in the UHF frequency band (860 MHz to 960MHz).
- **Voltage:** The two most common operating voltage options are 3.3 volts and 5.0 volts. 3.3 volts is considered to be a low voltage application. 5.0 volts is considered to be standard (Matthys, 78). Other less common operating voltages are available including voltages ranging from 1.8 V to 3.0 V.
- **Stability:** The most standard stability for a crystal oscillator is 50ppm. The stability is most dependent on the operating temperature range, and hence, 50ppm over  $\pm 70$  degrees Celsius is most common. 15 – 20ppm is normally considered to be the tightest production specification available, but special accommodations are possible for tighter specs. The better the cut of the actual crystal, the more stable the temperature response will be. Some high quality crystal cuts can reach as low as 10ppm. Another alternative is to use a Temperature Compensated Oscillator (TCOX). This type of oscillator has a temperature sensor and will adjust the applied voltage accordingly. It is common for ultra high frequency radio circuit oscillators to require an extremely stable oscillator. For that reason the group will likely select a TCOX oscillator.
- **Environment Temperature:** Generally, the industry standard operating temperature ranges from 0 to 70 degree Celsius. This is considered commercial temperature (Matthys, 78). Temperatures ranging from -40 to +85 degrees Celsius are considered industrial temperatures. These common ranges make up approximately 80% of all products available in the market (Matthys, 78). For common uses in military and automotive applications, some crystal oscillators can be designed for more extreme conditions. The higher the operating temperature specified, the higher the cost of the device.
- **Operating Environment:** This consideration is typically the first consideration when selecting a crystal oscillator. Careful considerations will be given to size constraints of this particular application. One of the requirements is a device that is lightweight and portable. PCB area will need to be kept to minimum.
- **Output Logic:** The most common output logic is CMOS/HTML. Other logics are available; however, CMOS is suitable for this application.



## 2.8 Wireless Communication Devices

The mobile reader for this project will require some method of communicating with a base computer that will house the GUI. The method that we choose will ideally be low power, reliable, size, cost, and simple to use. Speed of transmission is a secondary concern, but something that can still be important if it is too low. It was determined that we want the device we choose to be IEEE 802.15.4 compliant. During our research we looked at two main devices. Their strengths and weaknesses are discussed below.

### 2.6.1 CC2530

The CC2530 is a transceiver produced by Texas Instruments. The transceiver has a built in 8051 microcontroller. This microcontroller isn't extremely powerful, but could simply some parts of the initial setup of the transceiver and help with some of the basic protocol the GUI uses. The power required is very low and the rate of data transfer is very good. One of the downsides to this particular product is that it will require the use of a crystal and antenna to be used correctly.

### 2.6.2 Xbee Pro

This product is radio module produced by Digi. There are over 70 different versions of the product with varying power consumption, performance, and cost. The one we will look at is the Xbee Pro 60MW with attached wire antenna module. Unlike the CC2530 this module is ready to go right out of the box. The inclusion of the antenna and crystal in the unit make for a simpler setup. Xbee is very popular among hobbyists, so on-line documentation and other resources are readily available.

The size of the product that we choose will be an important consideration. The mobile device is being designed to be as unobtrusive as possible. Figure 9 shows the size of the Xbee pro. The CC2530 would ideally end up being about the same size once the crystal and antenna are installed.



Figure 9 – Size comparison of the Xbee pro (Reprinted with permission from sparkfun.com)

The basic specifications that we are looking for are pretty close to each other. The power output of the Xbee is much higher; however, since the reader won't be away from a charger for long lengths of time, this shouldn't be an issue. The decision on which product to choose really comes down to which one is going to be easier to use and has the most resources available for trouble shooting. The Xbee really stands out in that regard and ended up being our choice. There are 1000's of different projects that hobbyists have documented on-line. The ability to look through their projects to see where they have succeeded and failed prior to us putting the project through its paces is a huge benefit. The cost of two Xbees is also very reasonable for what we are receiving. The basic specs for these two options are listed in figure 10.

	CC2530	Xbee
Power Output	2.82 mW	63 mW
RF Data Rate	250 Kbps	250 Kbps
Frequency	2.4 GHz	2.4 GHz
Sensitivity	-97 dBm	-100 dBm
Supply Voltage	2-3.6 V	2.8-3.4 V

Figure 10 - Transceiver comparison

## 2.9 Battery Types

Since one of the requirements of our project is that it must be fairly small and portable, battery choice will be a big decision. There are many different types of batteries out there but a rechargeable battery is best suited for our project.

There are a wide variety of rechargeable batteries on the market, this include lead-acid, nickel cadmium (NiCd), nickel metal hydride (NiMH), lithium-ion (Li-ion), and lithium-ion polymer (Li-ion polymer). When looking at all of these, there is one in specific that we can already rule out and that is the lead acid battery. Most people know these as the battery that you can find in your car. These batteries work with a chemical reaction between lead plates and an electrolyte solution that is usually a diluted sulfuric acid. These batteries are usually capable of high current draws for a short period of time and are typically 12 volts. For our project we don't need as high of a voltage as 12 volts and we differently don't need to draw high amounts of current for a short period of time. The one deciding factor for not choosing a lead acid battery is the weight and size. Even a smaller lead acid battery can weight around 2 pounds and because of the portability needed for the reader unit this will not suffice.

The second type of rechargeable battery we considered is a nickel batter, either nickel cadmium (NiCd), or nickel metal hydride (NiMH). First we will discuss the nickel cadmium or NiCd battery. This battery has several advantages over the lead acid battery but with everything there are some disadvantages to the NiCd battery. One big advantage to NiCd batteries is that they are easy to charge and some can charge pretty quickly. When talking about charging batteries you usually refer to how you will charge the battery using C, where C is the amp-hour capacity of the battery. Using this, C/10 would mean that you supply the battery with 10 percent of its rated capacity for 16 hours to fully charge it. Some NiCd batteries thought are capable of charge rates up to 1C which means you supply 100 percent of the amp-hour capacity to the battery in 1 hour. Another advantage of NiCd is that they can be left in their discharged state for a while before charging them again without damage to the cells. Probably one of the most notable advantages of this type of battery is the cost. In terms of cost per cycle, NiCd is ones of the cheapest batteries on the market.

The second type of nickel battery to discuss is the nickel metal hydride or NiMH. When compared to the NiCd, many advantages can be seen. The first is that NiMH batteries have between 30 and 40 percent high capacity than NiCd batteries do. They are also less susceptible to the memory effect that NiCd batteries experience. This memory effect occurs when batteries are discharged and then charged many times to the same charge level and then battery remembers this level so that when it reaches it under normal use, there is a sharp voltage drop. The memory effect is actually caused by crystals growing inside the battery and the resistance increasing due to the larges surface area. Another advantage of NiMH batteries is that they are less toxic than NiCd. NiMH batteries are only mildly toxic compared with the cadmium that is in the NiCd

batteries. Some disadvantages are that they have a limited life and do not react well to overcharge. This means that you need a complex charger to make sure the battery is not overcharged.

The last type of battery that was researched is the lithium battery. Lithium batteries first showed up in the 1970s but it wasn't until the 1990s that they really became popular. Lithium-ion batteries are a significant improvement over NiCd with twice the specific energy. Like lead and nickel batteries, a lithium-ion battery consists of an anode, a cathode, and an electrolyte. For lithium-ion batteries the cathode is made out of a lithium metal oxide and the anode is made out of carbon. What most people don't know is that there is actually a wide variety of lithium ion batteries dependent on the actual material used for the cathode. All of these batteries have slightly different performance characteristics and qualities. The most common types of lithium-ion batteries are Lithium Cobalt Oxide, Lithium Manganese Oxide, Lithium Iron Phosphate, Lithium Nickel Manganese Cobalt, and Lithium Nickel Cobalt Aluminum Oxide. When comparing all of these batteries, the Lithium Nickel Manganese Cobalt or NMC, and Lithium Cobalt Oxide are on the higher side of energy densities, with between 140 and 180 Wh/kg. The last type of battery we discussed is the lithium polymer. A lithium polymer or lithium-ion polymer has all of the same characteristics as a traditional lithium-ion battery. The main difference is in the electrolyte material. In a lithium polymer battery, the electrolyte is a gelled micro porous electrolyte as opposed to the traditional porous separator. Lithium polymer does have a slightly higher specific energy but the cost on these batteries does increase between 10 to 30 percent.

After doing all of the research on batteries, it seems only logically to choose the battery with the highest specific energy and lowest weight which leads us to a lithium-ion polymer battery. Unfortunately with every great power source, also comes a risk of safety and catastrophic failure. Since lithium-ion batteries are capable of holding great amounts of energy, they are inherently dangerous if mishandled. Lithium-ion batteries can catch on fire or explode for a number of reasons. Heating the battery over a certain temperature or puncturing the battery can cause this to happen. Since our device will be enclosed and designed for use inside of a building, neither of these should be a concern. One last thing that can cause the failure of a lithium-ion battery is overcharging. The thermal runaway for the most common lithium-ion batteries is between 130°-180 ° C. Overcharging or even short circuiting the battery can cause the battery to heat up very quickly and then fail. Most lithium-ion batteries contain external safety circuitry that will trigger when there is a short or over charge condition and proper charging equipment and knowledge should prevent any problems. We only looked at 7.4 volt batteries since these should suit our project the best. All of the 7.4 volt batteries are two cell batteries, which means they are actually two 3.7 volt batteries connected together. Since the batteries are composed of two cells, we need to be careful how we charge them, which we will discuss in the next section. Shown below in figure 11 are several types of lithium-ion polymer batteries that might work for our project.

Manufacturer	Voltage	Capacity	Price	Weight	Dimensions
King Max	7.4 V	1000 mAh	\$6.95	85g	70mmx35mmx18mm
Lipo-Max	7.4 V	2200 mAh	\$15.95	206g	138mmx47mmx24mm
Trex Pro	7.4 V	500 mA	\$4.95	39g	55mmX31mmX13mm
Tenergy	7.4 V	2200 mAh	\$21.95	99g	67mmx37mmx18mm
Tenergy	7.4 V	5200 mAh	\$93.90	289g	133mmx41mmx24mm

Figure 11 - Different lithium-ion batteries choices

After looking over all of the batteries on the table above we were able to make a decision about one in particular. If we look at capacity we decided that 5200 mAh is probably more than we really need and that 500 and 1000 mAh might fall a little short of what we need. So that takes us to the two 2200 mAh batteries. Although the battery from Tenergy is cheaper, it only has one set of wires coming from the battery. The Lipo-max battery has separate charge and discharge wires and the charge wires have a JST-XH plug attached to them that fits in to a balancing charger. For these reasons we chose the Lipo-max battery to use in our project.

## 2.10 Battery Charging

Now that we know that we will be using a lithium-ion polymer battery we need to know how to properly charge it. Charging lithium-ion batteries is actually a 4 stage process and something you definitely want to do properly, both to prolong the life of you battery, and to keep it from blowing up. Shown below in figure 12 you can see the process and the status of the chargers current and the batteries voltage.

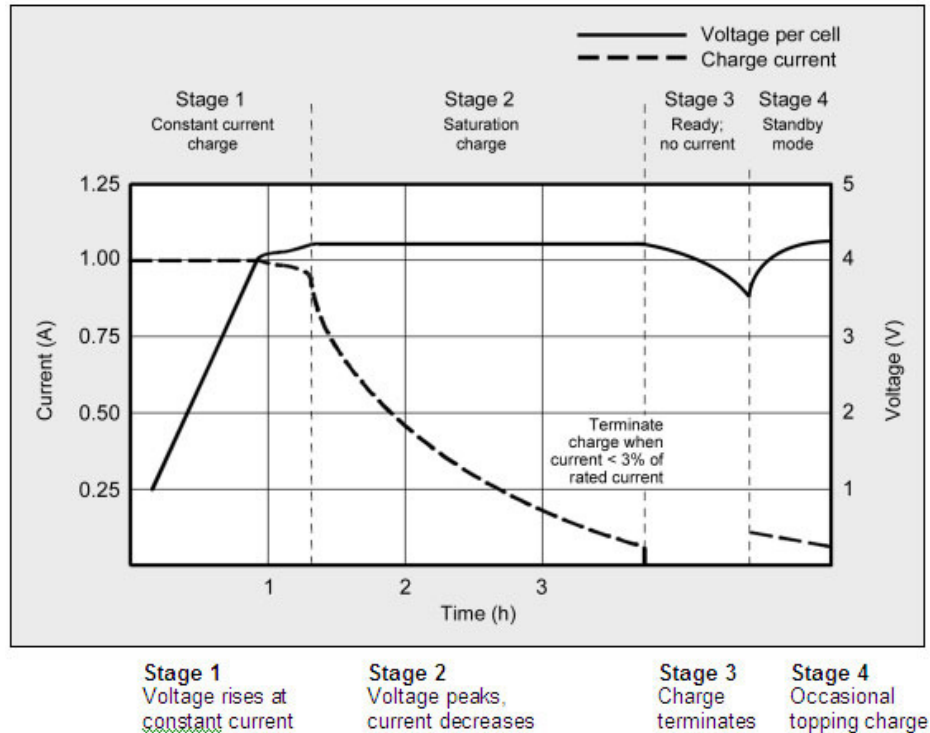

Figure 12 - Stages of charging a lithium-ion battery (Reprinted with permission from batteruniversity.com and Isidor Buchmann)

As you can see, the initial stage runs the battery between 0.5 and 1C until the voltage just gets over 4 volts. After that, the charger applies a current at a slight decreasing rate until the battery is fully charged. At this point all the charger will do is occasionally give the battery a short “top off” charge at a low current to get it back to its peak charge. Unlike other types of batteries, such as lead acid, a fully charged lithium-ion is not always desirable because high voltages can cause stress on the battery. If you only charge the battery up to say 70 percent, you can greatly increase the life on the battery even though the capacity won’t be too great.

Choosing a charger will be an important decision because we want to make sure to get the full potential from our battery for increased usage time. Since our battery will be 2 cells we need to make sure we get a charger that can properly charge both cells to the same level. The first charger we considered was a Tenery charger from batteryjunction.com. The charger is capable of charging all kinds of lithium-ion batteries including the lithium-ion polymer. It can also handle batteries with up to 6 cells, which will work fine for our battery. The only downside of this charger is the price at \$99.99. The second charger we considered is also made by Tenery and found on the batteryjunction.com website. This charger is only \$23.95 which is a huge improvement in price over the first charger. This charger’s specifications say it is capable of charging

batteries with up to 4 cells and a voltage range of 3.7-14.8 volts, but it says nothing about balancing the battery. Although the price is right, we want to make sure we get a charger that will balance the battery for safer operation. The last charger we looked at was from sparkfun.com and made by iMax. This charger is priced a little higher than the second one but still much better than the first at \$32.95. Like the first charger, this one is also a balancer and can handle batteries with up to 6 cells. The charger also has a small LCD screen and is capable of several programming features such as a time limiter.

## 3.0 Design

### 3.1 Tags

As you have seen from the research section, tags design fabrication and science is a field all in its own. For our project, we just needed to choose a tag that meets all of our requirements. One simple requirement is that we need a tag that is pre-programmed from the manufacturer with a unique ID. Alien Technology is a manufacturer of just about everything for RFID systems and their ALN-9640 “Squiggle” tag inlay meets our needs. Shown in figure 13 is the ALN-9640 tag inlay. The inlay is just the “guts” of the tag and is simply attached to a thin sheet of paper. For our purposes we don’t really need to enclose the inlay and will just need to mount it to something sturdy. Attaching the tag inlays to a small piece of poster board will probably be our best bet. The poster board is cheap and can easily be cut with scissors to the exact size that we need. Since poster board is thin it should not interfere with the tag as much as some other materials might.



Figure 13 - Alien Technology ALN-9640 UHF tag inlay (Reprinted with permission from Baxtek.com)

The key feature of this tag inlay that will suit our needs is that it comes pre-programmed with an unalterable 64-bit serial number. This will allow us to lay out our grid of RFID tags and know that every tag has a unique serial number that we will be able to program into our GUI. According to the data sheet on their website the tag is ISO 18000-6C as well as EPC Gen 2 compliant. The tag inlay is also able to operate at any worldwide RFID UHF frequency which ranges from 840-960 MHz. Some other features of this tag that we don’t really need are a 512 bit user memory and 32-bit access and 32-bit kill passwords. This is a neat

feature because it would allow us to set a password that would need to be used in order to access any of the information that we stored in the user memory.

## 3.2 Reader Unit

The heart and soul of this project is the RFID reader unit. This unit will be where the actual reading of the RFID tags occurs and where the data will be wirelessly sent to the GUI computer to be interpreted. At a high level, the RFID reader design will consist of three primary integrated circuit components: the RFID reader IC, the microcontroller, and the embedded wireless RF module. Show below in figure 14 is a simple block diagram of the reader unit.



Figure 14 - Reader Unit block diagram

The RFID reader IC will conduct the RF communication between the tags, and output serial data to the microcontroller. The microcontroller will then send that data, which will consist of the unique tag ID, to the Xbee wireless module to be sent to the receiving Xbee wireless module. The reader unit is a compact, portable, battery operated device. The overall design must be lightweight and easy to carry. Some of the challenges of the design were keeping the device lightweight and unobtrusive. The battery must be powerful enough to power the device through the day, but small enough to remain unobtrusive. The antenna and power amplifier must obtain maximum range while drawing little current from the battery. Similarly, the microcontroller and wireless RF module must be low power devices and have low area integration to the printed circuit board. A detailed design of the battery and power section, RFID reader IC, microcontroller, and wireless RF module will be discussed in the following sections.

### 3.2.1 Power

Power requirements are of course a very important consideration in a project, especially when the device is designed to be mobile. Since the device needs to be completely portable the first thing to worry about is a battery. Due to the requirements for the reader unit, a rechargeable battery will be best. We need



more than 7 volts to properly power the reader unit and this would require at least 5 non-rechargeable batteries such as an AA or AAA.

### 3.2.1.1 Battery

Sparkfun.com has a 2200mAh 7.4 Volt Polymer Lithium Ion battery for \$15.95. This battery will provide the needed voltage to the two voltage regulators that will be used to power the reader IC and the Xbee wireless module. The battery has two separate connections on it, a set of two wires for discharge, and a three wire JST-XH charge plug. The two discharge wires will be attached to a plug that will connect to a plug attached to the PCB and the charge plug will be left free to be attached to the charger when needed.

The approximate current draw for the entire reader module should be somewhere around 500 mA. With the 2200mAh battery we should expect the battery to last somewhere around 4 hours for continuous use. This number is calculated using the simple formula  $C=A*T$  where C is the battery capacity in amp-hours, A is amps and T is time in hours. When plugging our information in,  $2.2=0.5*T$ , T comes out to 4.4 hours. Since the module will not always be running at full power we can expect a slightly longer usage time of the battery but we will plan that the module will not be used for longer than 4 hours.

In order to charge the battery we will purchase a charger from sparkfun.com. The battery charger, which sells for \$32.95 is capable of charging and balancing a variety of batteries types such as Lithium Polymer, LiFe, NiCd and NiMH. Since the battery we will be using is actually comprised of 2 cells, it is important that it is charged properly and that the 2 cells are balanced so that they are both charged up equally. We will purchase 2 batteries to make sure we have an ample amount of power to conduct all of our testing without having to wait for a battery to charge. The system will be designed to be used for a few hours during the day and will the battery will then need to be charges. Since the charging plug will be able to be accessed from an opening in the enclosure, the unit will simply need to be plugged in to the charger without the need to open the case and disconnect the battery. Shown below in figure 15 are the battery and charger from sparkfun.com.



Figure 15 - Lithium polymer battery and charger (Reprinted with permission from sparkfun.com)

### 3.2.1.2 Voltage Regulators

Since the reader IC and Xbee require two separate voltages, we decided that each part should have its own voltage regulator that are both connected in parallel with the battery. The reader IC is the heart of the reader module and due to the cost of the part, we need to be very careful to make sure we do not burn it out by applying too high of a voltage. According to the data sheet for the AS3992 the supply voltage for the chip should be between 5 and 5.5 volts. The typical current requirements for the chip with the internal power amplifier on are 260 mA. Using these 2 parameters allowed us to pick out a voltage regulator from Texas Instruments. The regulator we choose is the TI uA78M05. The regulator takes an input of between 7 and 25 volts and outputs 5 volts and 500mA. The voltage regulator will be in the TO-92 package so that it will be easy for us to solder onto the PCB and easy for us to replace if we have any problems.

The second part of the reader that needs power is the Xbee wireless communication module. Again looking at the data sheet for the part, it requires 3.3 volts and 50mA. Using Newark.com we were able to find a suitable voltage regulator. The voltage regulator is a ST Microelectronics L78L33ACZ. The regulator can take in between 5.3 and 30 volts and will output 3.3 volts and 100 mA. Like the 5 volt regulator, the 3.3 volt will be in the TO-92 package for easy attachment and removal from the PCB.

Controlling the power to the device will be done with a simple SPST slide switch attached in series after the battery before the regulators. To determine that the device is on, we will have a green LED attached after the 5 volt regulator that will light up when we flip the switch.

Capacitors in parallel at the input and output of the voltage regulator will help with any noise and make sure that the output voltage is as clean as possible. In the data sheet for the 3.3 volt regulator they have their test circuit in which they used a 0.33  $\mu$ F capacitor for the input and 0.1  $\mu$ F for the output. We used these same values, 330 nF and 100nF, for our circuit as they should most closely give the

results found in the data sheet. In figure 16 below you can see the schematic of the power system with the regulator and capacitors described.

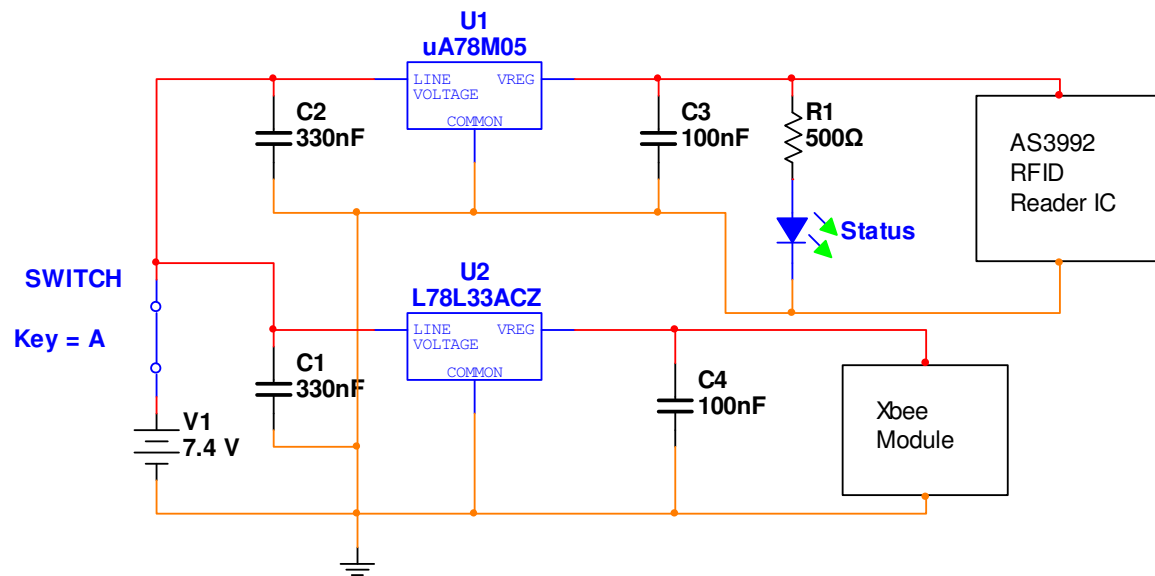

Figure 16 - Power circuit for the reader unit

### 3.2.2 LED Indicators

It will be important to have several indicators showing the status of the device. The first LED indicator is already tied into the power circuit from section 3.2.1.2 and will simply light up when there is a battery connect with sufficient voltage to supply the 5 volt regulator. Since our device will be portable and battery operated, a low battery indicator should also be incorporated into the design. Our device is also a radio so it would also be good to know when the unit is emitting radio waves. The Xbee unit will be constantly transmitting so the main focus on the RF LED indicator will be for the reader chip to know when it is actually transmitting. For all of the LED indicators we will use LEDs from newark.com. The LEDs have a forward voltage of 2.1 volts and a forward current of 10mA. The LEDs are made by Avago Technologies and are \$0.70 a piece, and we will need 1 green, 1 red, and 1 blue.

#### 3.2.2.1 Low Battery Indicator

It will be important to know when our battery is getting low so that it can be recharged or replaced. Our battery is a 7.4 volt lithium-ion and it is connected to a 5 volt regulator. Since the regulator needs at least 2 volts higher than its output, it needs at least 7 volts. This means that our low battery LED should light up when the battery drops to 7 volts because it will no longer be able to properly

power the voltage regulator. We are using a green LED to show when the unit is turned on so we can use a red LED to show when the battery is low.

After doing some research online on low battery indicator circuits one in particular seemed well suited for our project. The website [www.extremecircuits.com](http://www.extremecircuits.com) has a low battery circuit that works for voltages up to 12 volts. The circuit uses a 1N914 diode, two 2N2222 transistors, three resistors, and a potentiometer. The potentiometer is 100k ohm and can be adjusted for the desired voltage level to turn on the LED. When the voltage drops below that amount that is set by the potentiometer, the first transistor turns off, allowing the second to turn on and light the red LED. After some simulation in Multisim, it was found that setting the potentiometer to 35 percent results in the LED turning on when the source, our battery, drops to 7 volts. Shown below in figure 17 is the circuit for the low battery indicator.

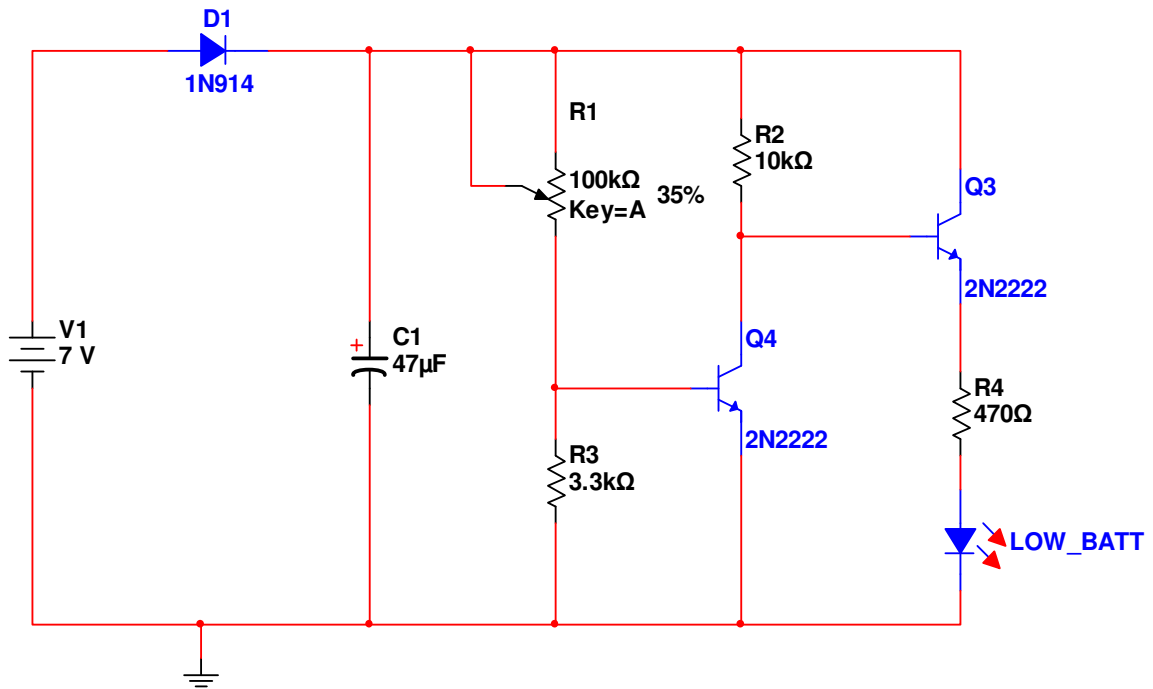

Figure 17 - Low battery indicator circuit

Having a potentiometer in the circuit can also prove to have some advantages. It is possible that during testing we would want to adjust the level at which the indicator will come on. In this case we would just increase the resistance on the potentiometer. It is also possible that during some stage of prototyping that we will choose a battery with a higher voltage. Again we can just increase the resistance of the potentiometer accordingly.

### 3.2.2.2 RF Transmit Indicator

Since our project involves the transmission of radio waves that we can't see, it might be important to have a LED indicator that will light when our project is transmitting a radio signal. We know that the Xbee module uses radio to communicate but since it will be almost constantly on, will focus more on the radio waves being transmitted from the reader chip to the tags.

The actual circuit for the RF transmit indicator LED will be very simple. The circuit will consist of just a resistor, transistor, LED, and two capacitors. The LED will be connected after a BJT transistor that will be connected to the battery. The 2N2222 transistor will be connected to the RF output of the reader IC. Whenever the reader IC transmits RF the transistor will turn on allowing current to pass to the blue transmit indicator LED. Shown below in figure 18 is the RF transmit indicator circuit.

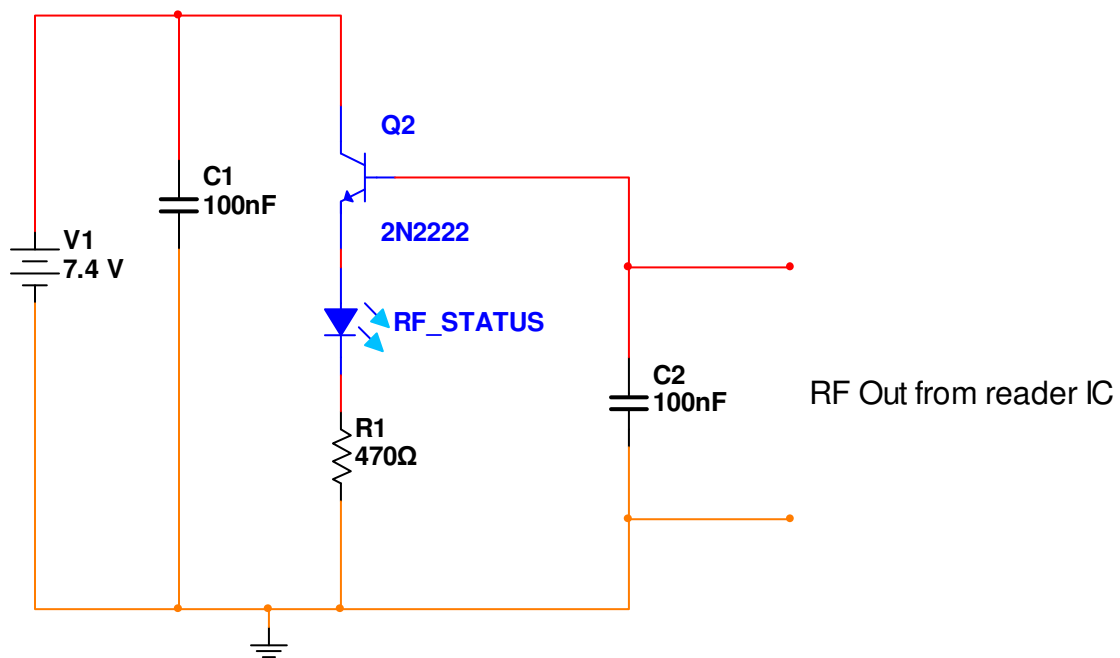

Figure 18 - RF transmit indicator circuit

### 3.2.2.3 Complete Power and Indicators

The two indicator circuits, the low battery and RF transmit, will connect in parallel to the main power circuit that contains the regulators, and the LED to show that the device is powered on. Shown below in figure 19 is the complete circuit diagram with both indicator circuits connected to the main power circuit.

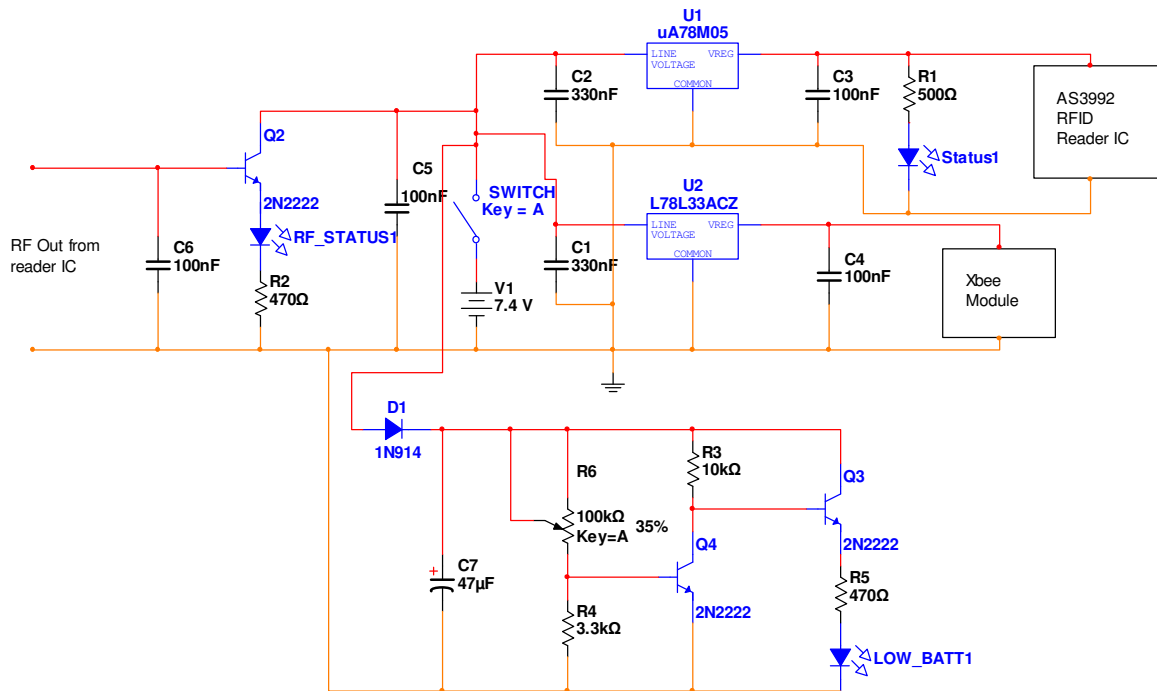

Figure 19 - Complete power circuit with LED indicators

### 3.2.3 RFID Reader IC

The AS3992 chip from austriamicrosystems is the UHF reader IC selected for this design. The AS3992 is a UHF Class1 Gen 2 single chip with integrated analog front-end and protocol handling compliant with the ISO 18000-6c/b standards. This chip was selected for its robust design, high performance, and low cost. A consumer in the market for a UHF RFID integrated circuit has many options and is faced with the task of selecting the one that is appropriate for the application. Figure 20 shows some of the key features considered when selecting this chip.

Key Features	AS3992
UHF frequency range	840 - 960 MHz
High receive sensitivity	-86dBm
ASK modulation	Yes
Internal PA for testing	Yes: 20dBm
USB powered for testing	No step conversion needed
Output Power	20dBm
Integrated supply voltage regulators	Yes
Support for external MCU circuitry	3.3 V regulated Up to 20 mA
Serial Peripheral Interface	Yes
Low power consumption	120mA, 5.3V typ
Small footprint	9mm x 9mm
FCC US regulation compliant	Yes
Low cost	\$83.49

Figure 20 – AS3992 Key Features

The communication between the reader and transponder follows a reader talk first method. The reader will send out an interrogation signal and wait for a backscatter response. The reader will function as a slave to the microcontroller (master). The host system initiates all communication to the reader IC; however, the reader does have an interrupt pin (IRQ) to request attention from the microcontroller. As the reader receives power, the IC is configured with default register values and the host system initiates communication by turning on the RF field. This is done by setting the control register (00) bit rf\_on. The initial RF field ramp-up time is adjustable. The available values are 100µs, 200µs, and 400µs. For initial testing, the default (Tari determined) will be used. The default pulse width is 0.5 Tari. The transmit length is 2 Tari and the RTcal is 133µs. The rf\_ok bit of the 'AGC and internal status register' (0E) is set high when the ramp-up is complete. This allows the host system to check ramp-up status and force the RF field down when needed by setting the rf\_ok bit low.

### 3.2.3.1 Pin Connections to Reader IC

The AS3992 is a robust IC capable of supporting many different RFID applications. The package is a 9x9 (mm) QFN-64, and a major part of the project design is the surrounding circuitry feeding to/from each of the 64 pins in order to achieve the desired functionality.

The device is powered through the VEXT and VEXT2 pins, and is enabled by setting the EN pin high. The recommended supply voltage to VEXT and VEXT2 is 5 volts. A set of 3.4 volt regulators is used to supply the reference block, analog /digital converters, low frequency receiver cells, the RF part, and the digital part shown in figure 21. Input to the regulators are supplied from the VEXT 5V coming into the chip. The output of the regulators is then distributed to VDD\_D (used to supply the MCU), VDD\_A, (analogue out - not used), VDD\_LF (used for low frequency processing), VDD\_RFP, and VDD\_B (output for PA buffer – not used). See Figure XXX for regulated input/output. Each of these pins need to be stabilized by connecting two grounded capacitors in parallel. Capacitor values suggested by austriamicrosystems are between 2 to 10  $\mu\text{F}$  and 10 to 100  $\mu\text{F}$ . See design summary for specific placement and values.

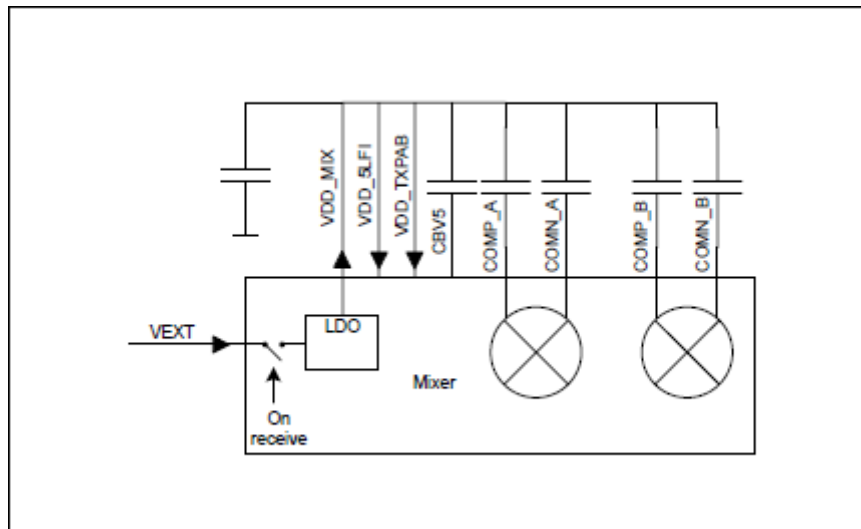

Figure 21 – Regulated Inputs and Outputs

Internal level shifters are integrated into the reader IC. This is to help prevent communication interference to the microcontroller. A separate supply pin (VDD\_IO) is used to supply the level shifters. VDD\_IO is tied directly to VDD\_D to ensure proper communication between MCU and reader chip. VDD\_D supplies the MCU.

The chip comes integrated with an internal voltage controlled oscillator, phase-locked loop block, charge pump, and phase-frequency detector. Users have the



option of using these internal components, which are optimized for 860 MHz to 960 MHz, or use an external RF source. The fully integrated components are suitable for the purpose of this system application. The control input for the VCO is the VCO (pin 60) and is designed to support a maximum of 3.3 V. The charge pump (CP - pin62) will supply this input. The amperage out of the charge pump is adjustable from 120 $\mu$ A to 2350 $\mu$ A by setting the cp<2:0> bits of the CL\_SYS, Analog Out and CP Control register (14). For the initial set-up and testing, we will use the default 120 $\mu$ A. To generate the relatively high carrier frequency (915MHz) the internal VCO will be used. The VCO has a frequency range of around 1800MHz. The tuning range can be manually configured by setting option bits vco\_r<3:0> in register 14. This setting is a function of the frequency dependence setting (increasing or decreasing with VCO voltage) and the charge pump current. The tuning range can also be set to automatic using the default values of the same register. An external loop filter is needed for this arrangement. This filter consists of only a few passive components. Figure 22 shows the design of the loop filter circuit.

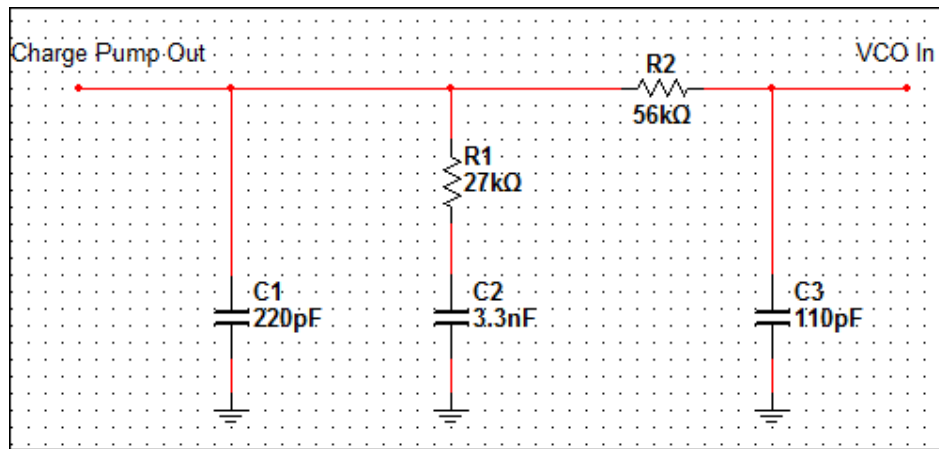

Figure 22 – Loop Filter Circuit

The loop filter components were calculated to satisfy each of the following parameters.

- Charge pump current – 1.2mA
- Carrier frequency – 915MHz
- Reference frequency – 50kHz
- Internal VCO configuration

EXT\_IN (pin 56) is an RF input from an external VCO. This pin is not use and is left open. ADC (pin 58) is an input for an external power detector. This pin is not used and tied to ground. VSN\_CP (pin 57) is a negative input for an external charge pump. This pin is not used and is tied to ground. VSN\_A (pin 59) is an analog part positive supply, internally regulated to 3.4V. This pin is not used and is tied to ground. Pins CD1 (53) CD2 (52) are bidirectional internal node de-

coupling capacitors. AGD (pin 54) is a bidirectional analog voltage reference. These three pins are de-coupled and tied to a common ground. See Figure 23 for component values and layout.

VDD\_5LFI (pin 5) is a positive supply for the low frequency input stage of the IC. This pin connects to VDD\_MIX (pin 13) which is a positive supply output from the mixer and is internally regulated to 4.8 V. COMP\_A, COMN\_A, COMP\_B, and COMN\_B (pins 64, 1, 2, and 3 respectively) are bidirectional to an internal node. These pins are connected to de-coupling capacitors and connected to VDD\_5LFI. DAC (pin 4) has an output resistance of 1k $\Omega$  and is a digital to analog converter for an external power amplifier. This output is not used in this design and is left open. VSS and VSS2 are supply inputs for substrate. These inputs are not used and are tied directly to ground. VSN\_MIX is a negative mixer supply input. This input is not used and is also grounded.

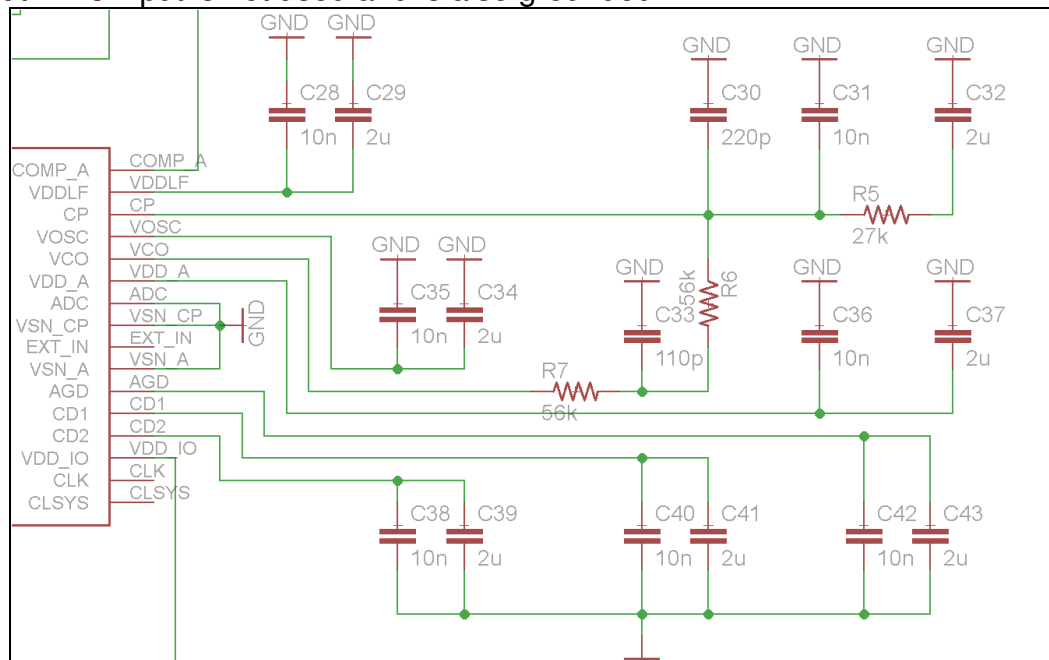

Figure 23 – Reader Schematic for Pins 49-63

This chip has a pair of input mixers that are driven with 90° shifted local oscillating signals and forms an IQ demodulator circuit, see Figure 24. By using the IQ demodulator, the amplitude modulated input signals are demodulated in the in-phase channel and the phase modulated input signals are demodulated in the quadrature phase channel. Mixed input modulation is also supported by the AS3992 chip in which both channels are used. This is useful if the tag protocol is unknown or if the reader is to be used in a diverse setting that uses both AM and PM. Phase modulation will not be used in this design. MIX\_INP and MIX\_INN (pins 7 and 9) are positive and negative inputs to the differential mixers. These inputs can customize the differential input and should be AC coupled if used. The consequence of using these pins is a lower or higher input range for the mixer.

The differential mixer will not be used in this application and pins 7 and 9 will be left open.

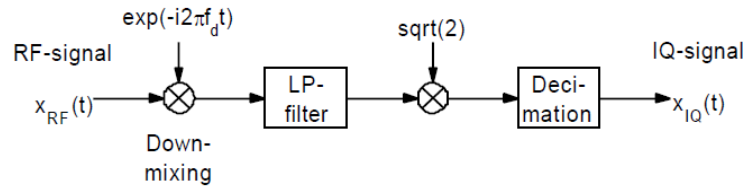

Figure 24 – IQ Demodulator

The chip also has a single ended mixer available and will be used in this design. The single ended mixer input is selected by setting the `s_mix` bit in the 'Rx Special Settings' register (0A). `MIXS_IN` (pin 10) is the single ended mixer input and is AC coupled. The noise level and dynamic input range of the receiver can be optimized by setting the single ended mixer to a custom input range. The performance of the mixer is then adapted by an internal attenuator or by increasing the mixer gain. It is possible for the receiver's RF input voltage to reach a level that disturbs the mixer performance. Things that can cause this to happen are particular environment reflexivity or the antenna performance. If this occurs, the input range of the mixer can be increased by setting bit `ir<1>` of register 0A. To separate transmit and receive path, a directional coupler is used. Between the power amplifier and directional coupler respectively between the directional coupler and the input pin (`MIXS_IN`).

`CBIB` (pin 12) is a bidirectional to an internal node. This pin is de-coupled with a capacitor to ground. `CBV5` (pin 14) is also a bidirectional to an internal node. This pin is de-coupled and connected to `VDD_MIX`. `VDD_TXPAB` (pin 15) is a positive supply input for an internal power amplifier bias and is connected to `VDD_MIX`. Figure 25 shows the layout and capacitor values for pin connections 1-17 and 64.

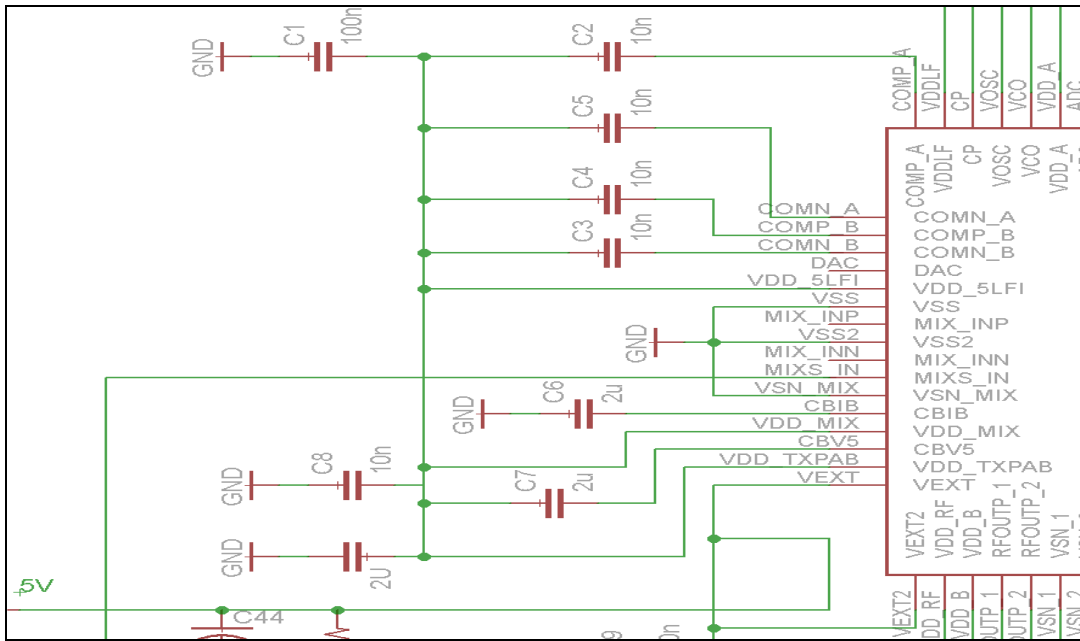

Figure 25 – Reader Schematic for pins 1-17 and 64

VDD\_RF (pin 18) is a positive regulated supply output. This output is internally regulated for 2V – 3.5V. Typical operation is 2.0V. This pin is connected to decoupling capacitors and connected in parallel to the RF matching network. VSN\_1 through VSN\_5 are negative supply inputs to power amplifier. These pins are connected directly to ground. VSN\_D is a negative digital supply that is not used in this design and is also tied to ground.

OAD and OAD2 (pins 31 and 30) are bidirectional analog or digital received signal outputs. These pins are connected to 10kΩ resistors. If the power down mode is to be used, OAD2 should be left open for correct operation. We have decided to connect these pins to grounded resistors in order to have the option to use the power down with MCU support mode. The resistor is necessary only during EN = Low, EN Low-to-High transition, and EN High-to-Low transition. It is not necessary during reception. This power mode is not part of the designed operation but may be used for testing purposes. If direct data mode (discussed in the next section) is to be used, analog sub-carrier signals of both receiving channels are enabled by setting the option bit dir\_code high in the 'CLSYS, analog out, and CP control register (14). OAD and OAD2 are the output pins. RFONX and RFOPX (pins 32 and 33) are low power linear negative and positive RF outputs. These outputs can be used to drive an external amplifier. To enable the output, the ext<1:0> bits in the 'Regulator and IO control' (0B) register need to be set according to the desired current output level. There are 4 different states for this low power output. Figure 26 shows each of the four states and their register bit setting.

Bit	Signal Name	Function	Comments
B1	Ext<1>	Enable for low power output and current for auxiliary driver low power output	00:disabled 01:7mA 10:14mA 11:22mA
B0	Ext<0>		

Figure 26 - Low Power Supply Output Status

This low power linear output is not needed for this design. These pins will be left open and ext<1:0> bits of register 0B will keep the default value 00 for disabled mode. RFOUTP\_1 and RFOUTP\_2 (pins 20 and 21) are the positive RF outputs from the internal power amplifier. These pins are tied together and connected to matching network (discussed in a later section). RFOUTN\_1 and RFOUTN\_2 (pins 27 and 28) are the negative RF outputs used in single ended mode. These pins are tied together and connected to the matching network. For correct operation, the matching network needs an RF choke and match impedance for 50Ω. This is discussed in more detail in section 3.2.3.2. The power output is about 20dBm and is used for driving the antenna. The internal power amplifier is enabled by bits ext<3:2> of the Regulator and IO control register (0B). The output of the power amplifier is adjustable from 7mA to 22mA. The internal power amplifier can also be disabled (option bits set to 00) if an external PA is to be used. The bit configuration options of ext<3:2> from register 0B are identical to bits <1:0> of the low power supply output shown in figure 29. For initial testing, the default value of 7mA will be used. It is desirable to get a maximum read range from the reader IC while consuming as little power as possible. Achieving a high read range is a beneficial design quality for two primary reasons. First, with a longer read range, a larger of number of tags can be detected at any instant. The more tag ID's read into the computer at any sampled instant, the more data the computer has to calculate expected location of the individual, and thus, improving accuracy. Second, with a longer range, the tag mesh density can potentially be reduced. A less dense tag mesh lowers the cost of implementation. There is a design trade-off between mesh density and tracking accuracy. There is also a design trade-off between read range of the reader and power consumption from the battery. The minimum goal for satisfactory performance is a range of at least 2 m<sup>3</sup>. The minimum number of tags detected at any sampled instant is two tags. The minimum desired charge life from the battery is 8 hours. It is expected to need higher than the default 0.7mA from the PA to achieve the minimum range goal of 2 square meters. During the testing phase, each of these power amplifier settings will be carefully tested to determine the minimum and maximum read ranges. The minimum power from the PA required to meet the range specification will be used. The minimum number tag per square meter required to meet the accuracy specification will be used. These parameters are optimized for the lowest cost and lowest power consumption to meet the desired accuracy specification. Figure 27 shows the schematic layout with component values for the reader pin connections 17 through 33.

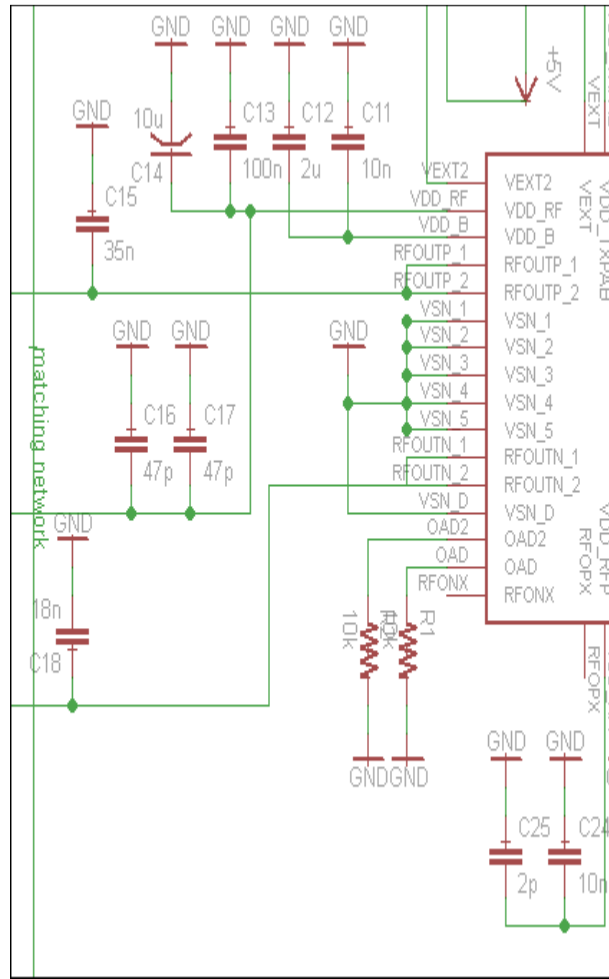

Figure 27 - Reader Schematic for pins 17 – 33

A reference frequency of 20MHz is needed for the AS3992 chip. The chip supports either the conventional quartz crystal oscillator or the TCXO for the external reference oscillator. The crystal should be accurate to 10ppm which is a relatively high accuracy. The quartz crystal oscillators that were found were either not accurate enough or too expensive. For this reason the TCXO oscillator was chosen. Also, the Temperature Compensated Crystal Oscillator (TCXO) has better temperature stability than most of the quartz oscillators that were found. The oscillator is discussed in more detail in section 3.2.3.5. The oscillator is connected between OSCI and OSCO (pins 36 and 37) with load capacitors between the oscillating pins and ground. IO0 through IO7 (pins 41 through 48), EN (pin39), IRQ (pin 40), and VDD\_D (pin38) are for communication to host controller and are discussed in detail in section 3.2.3.8. VSN\_RFP (pin 35) is a negative supply input for the RF path. This pin is not used and is tied directly to ground. Figure 28 shows the schematic layout for pins 34 through 48.



has a wideband frequency range of 600MHz to 1100MHz. It has a balanced transmission line and amplitude unbalance of about 0.60 dB. The phase unbalance is 8 degrees typical. One of the reasons this chip was selected is the low insertion loss (about 0.37dB at 915MHz). The component placement and network layout is done according to the reference design suggested from the manufacture. See the XFMR\_TCML1-11 datasheet in the appendix section. Deviation in the symmetrical filter and balun may cause reduced output power, higher harmonics level, higher TX current consumption and reduced sensitivity. The layout of the single ended filter towards the antenna is less critical in terms of placement because the impedance is approximately 50 Ohms. Figure 29 shows a schematic layout of the matching network.

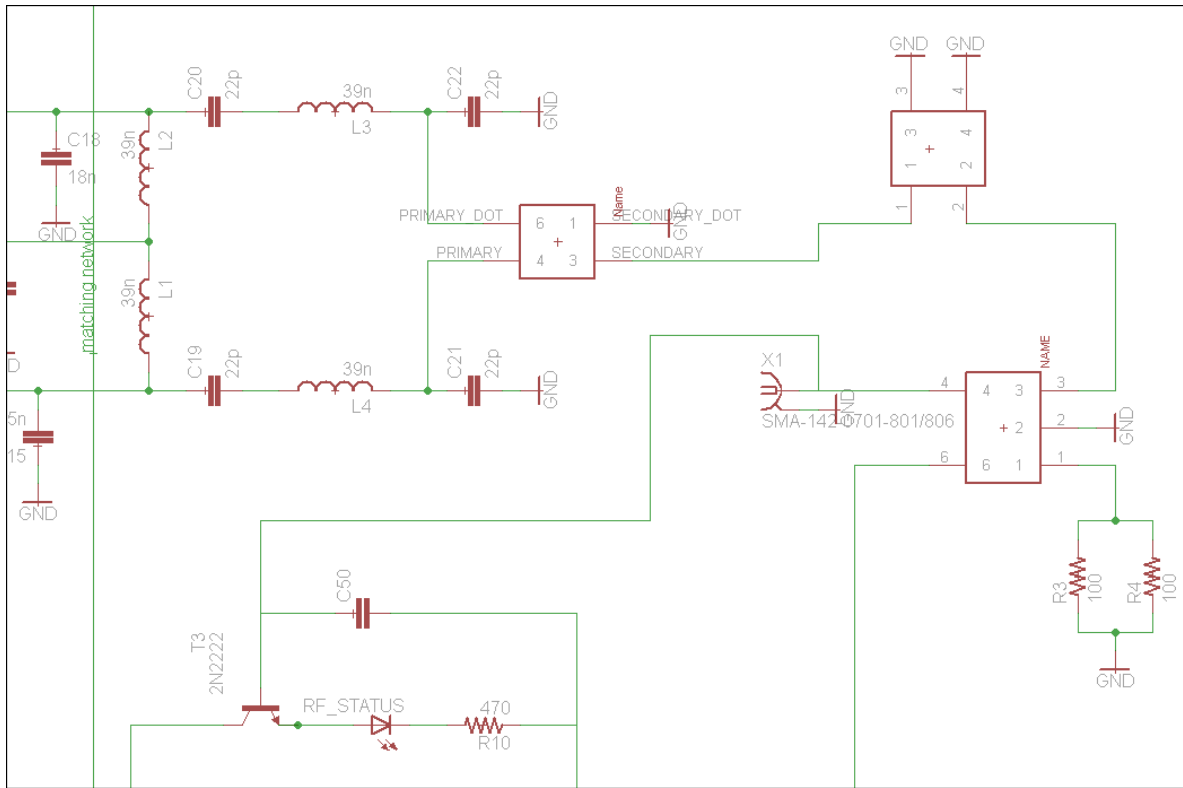

Figure 29 - Matching Network Schematic Layout

### 3.2.3.3 RF Low Pass Filter

A low pass filter is used to filter out the second and higher harmonics generated from the power amplifier. The LFCN-1000D low pass filter from Mini-Circuits is used in this design. This filter was chosen for its low cost, small size, power handling, and low insertion loss. The LFCN-1000D causes almost no signal power loss at 915 MHz.



### 3.2.3.4 Directional Coupler

A directional coupler is used to isolate and separate the receive path from the transmit path. The XFMR\_TCD-13-4 from Mini-Circuits is used in this design. This coupler has a 1.20 VSWR which will minimize low mismatch errors and improve measurement accuracy. At 915 MHz, coupling is about 12.5 dB. The total loss in the main line of direction is approximately 0.95 dB. This includes insertion loss and coupling loss. This application requires relatively high isolation for the two opposite-travelling signals. The typical directivity of this coupler at 915 MHz is about 14.7 dB and about 22.8 dB return loss.

### 3.2.3.5 Oscillator

Crystal oscillators are generally stable devices; however stability can be affected by temperature. It is known that the cut of the crystal element can help minimize the effects of temperature however high quality cuts tend to drive up the cost of the oscillator. A low cost solution to help control the effects of temperature is the use of a temperature compensated oscillator (or TCXO). A TCXO will adjust the frequency of the oscillator to compensate for the changes that result from the operating temperature change. This is achieved with the use of a voltage controlled crystal oscillator (VCXO). This uses a temperature sensor to provide a voltage feedback to correct the oscillator. The performance of a TCXO is typically better than a standard quartz oscillator. The desired performance for this design is 10ppm. To achieve the desired specifications, the TSX-3225 series crystal oscillator from Epson Toyocom is used in this design as the reference oscillator to the reader IC. The frequency range is from 16MHz to 48MHz and has a fundamental mode of vibration. The oscillator will be supplied with a regulated 3.3 V and operate at 20MHz. The oscillator will be connected to the OSCI input and OSCO output. Figure 28 shows the schematic layout of the oscillator. This particular oscillator was picked for its small footprint, low cost, frequency range and drive power (100 $\mu$ W or less). Figure 30 show the dimensions of the device.

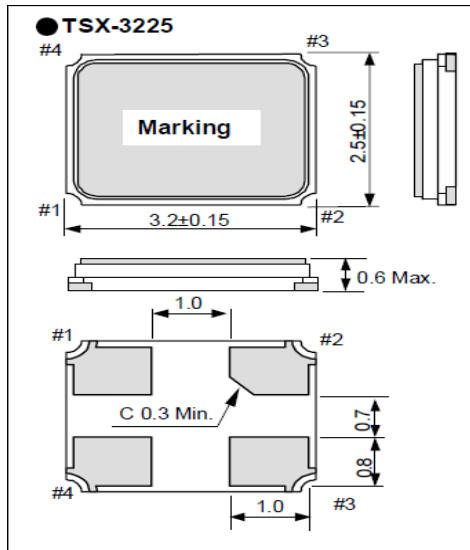

Figure 30 – TSX-3225 Dimensions

### 3.2.3.6 Antenna

A directional antenna is typical to most RFID designs sense the tag orientation is usually known. For example, using a handheld reader to scan a pallet of freight as it is being checked in, or reading the transponder mounted in window of a vehicle as it passes through a toll booth. The designers of these systems use the general known location of the tag to maximize antenna gain in that direction. When using RFID to track the location of an object within a three-dimensional space (or 2-D for single level buildings), the orientation of the tag is not necessarily known. In this case, a unity gain or omni-directional antenna is desired. The antenna used in this design is the P915-SMA-2 from Comtelco. It is a portable quarter-wave dipole with unit gain from 902MHz to 928MHz. The design is a highly durable straight connector with a textured finish. It is given a power rating of 50 watts, a standard impedance of 50 ohms, VSWR of 1.9:1, and has a vertical polarization. The length is 2.1” and it has an SMA connector plug (male). The antenna will connect to the PCB mounted MMCX-J-P-H-ST-1 female SMA connector.

### 3.2.3.7 Power Modes

The IC chip is capable of five different power modes: Normal, Stand-by, Power Down, Power Down with MCU Support, and Temporary Normal Mode. Figure 31 provides a description of each mode and the required pin values.

Power Mode	EN	OAD2	Std by	Description
Power Down	L	-	X	No power is distributed through input regulator stage.
Power Down w/ MCU	L	10k to GND	X	VDD_D is enabled in low power mode and CLSYS is 60 KHz.
Normal Mode	H	X	X	All supply regulators, reference voltage system, oscillators and PLL are enabled.
Stand by		X	H	Regulators, references and oscillators are in LP. PLL, transmitter and receiver are off. Register values are saved.
Temp Norm	L	10k to GND	X	Checks power status every 200 $\mu$ s.

Figure 31 - AS3992 Power Modes

This design will utilize only one of the power mode options available from the reader IC. The reader system will be powered by a rechargeable battery operated by a two-state switch. After the battery has been charged, and the device is ready for use, operation will be controlled by a power switch. When the switch is in the on state, the device will be fully active and operating in Normal Mode. The device will enter normal mode by receiving a command from the microcontroller transitioning the EN bit from low to high. When the chip is in normal mode, all supply regulators, crystal oscillator, reference voltage system, RF oscillator and PLL are enabled. After the oscillator stabilizes, the CLSYS clock becomes active with a default frequency of 5MHz.

### 3.2.3.8 Data Modes

The device allows for two possible modes to transmit and receive data: Normal Mode and Direct Mode. None of the data processing or buffering is done internal to the reader IC with Direct Mode. All signal processing is handled by the host controller. This option will not be used in this design. In Normal Mode, the transmit and receive signal processing is done internal to the IC. This includes

protocol coding, adding preamble or frame-sync, signal shaping, modulation, and cyclic redundancy check (CRC). Normal data mode will be used in this design. The TX and RX data passes through a buffer register using twenty-four bit first-in-first-out protocol (FIFO). This register is loaded in a cyclical manner. The register (and pointers) should be cleared by the reset command (0F) before each FIFO write for transmission. When data comes from the host controller, it gets stored in the FIFO register at address 1F from 0 to 23. There are three flag bits for the FIFO register.

- Overflow
- Low byte count during transmission
- High byte count during reception

When the bytes are loaded into the reader, there is a counter that counts the number of bytes loaded into the register. Likewise, when data is read from the FIFO register, an output counter is used to keep track of data flow and set status flags accordingly. The input and output counters are 12 bits each. If the number of bytes in the FIFO register is less than 6, the control sends an interrupt request to the host controller by setting the IRQ pin. If the number of bytes exceeds 18, an interrupt request will be sent to the host. These interrupts allow the host controller to add new data or remove data as needed. The counter also checks that the number of bytes to be sent does not exceed the set transmit length.

The AS3992 has a receive signal strength indicator (RSSI). As the reader periodically interrogates the near-field area, it listens for identifying backscatter. The received signal will pass by a meter that will measure the relative signal strength. The meter will measure peak-to-peak demodulated voltage sitting on the receive channel during reception. The peak-to-peak value of each RSSI meter is stored and presented in the 'RSSI levels' register (0F). The RSSI register is only valid until the start of the next transmission. The register will contain a 4-bit value for the Q channel and a 4-bit value for the I channel. This means that each channel can be metered at 16 different values. Each value represents 2 dB per step. These can be read from the register into the microcontroller and used as coefficients in the algorithm to calculate a more accurate target location. Figure 32 shows the RSSI register organization.

Bit	Signal Name	Function	Comments
B7	rss<7>	RSSI value of Q channel	(16 steps, 2dB per step)
B6	rss<6>		
B5	rss<5>		
B4	rss<4>		
B3	rss<3>	RSSI value of I channel	(16 steps, 2 dB per step)
B2	rss<2>		
B1	rss<1>		
B0	rss<0>		

Figure 32 - RSSI Levels Register (0F)

### 3.2.4 Enclosure

As with any electronic device that is meant to be portable, a durable, protective enclosure is important. Since the reader unit is meant to be carried on or by a person, the enclosure should be as small as possible while still providing protection to shock, moisture, and general abuse. The best material to choose that will satisfy all of our needs is ABS plastic. The website [www.proto-advantge.com](http://www.proto-advantge.com) sells a wide variety of ABS plastic cases in many shapes, sizes, and colors.

The website sells a black ABS case that is 5.12 inches long by 2.56 inches wide and 0.97 inches high. The case should have no problem accommodating a lithium-ion battery as well as the printed circuit board. Due to the tightness of the case, the battery will need to sit at the bottom with the circuit board on top of it. Shown below in figure 33 is a picture of the plastic case.

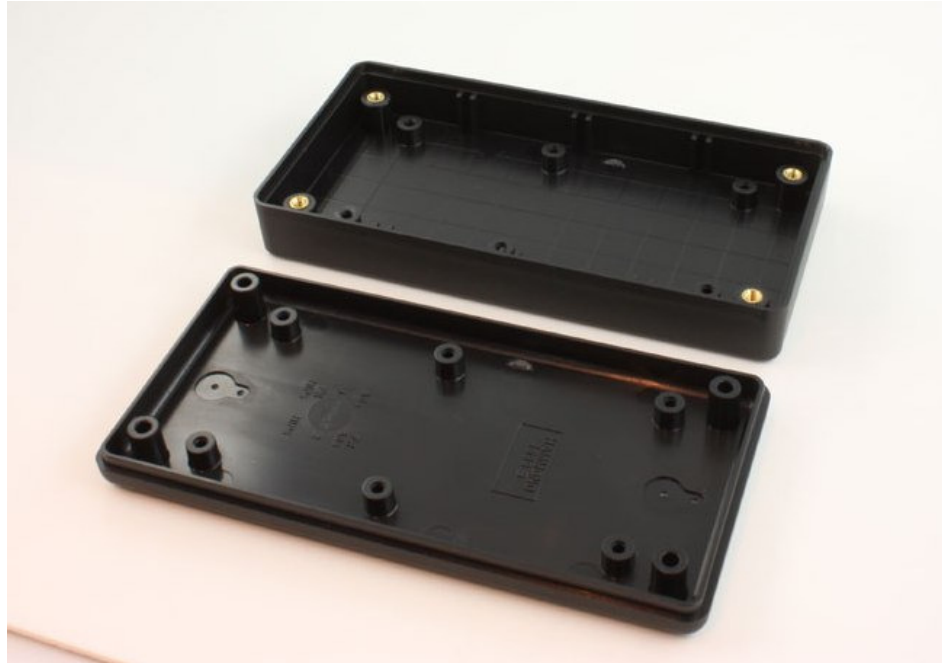

Figure 33 - Black ABS plastic enclosure (Reprinted with permission from [www.proto-advantage.com](http://www.proto-advantage.com))

As you can see from figure 33, the case comes in two pieces that you can then close with four screws around the edges. There are also small holes in the case in which you can screw down the PCB so it does not move around. Some of these holes will interfere with everything being able to fit inside so they will either need to be ground small or completely cut off.

Once closed, it can be seen that this case has no openings. This will be a problem as we have three LED indicator lights, an on-off switch, an antenna, as well as a battery charger that need to come through the case. The best and easiest solution to this problem is to take a normal drill and drill the three small holes for the LEDs, the small rectangular hole for the switch, and the larger rectangular hole that will fit the JST-XH plug for charging the battery. Shown below in figure 34 is a complete diagram of the case with the placement of the battery and printed circuit board, as well as the drilled holes for the LEDs and battery charging cable as well as the antenna.

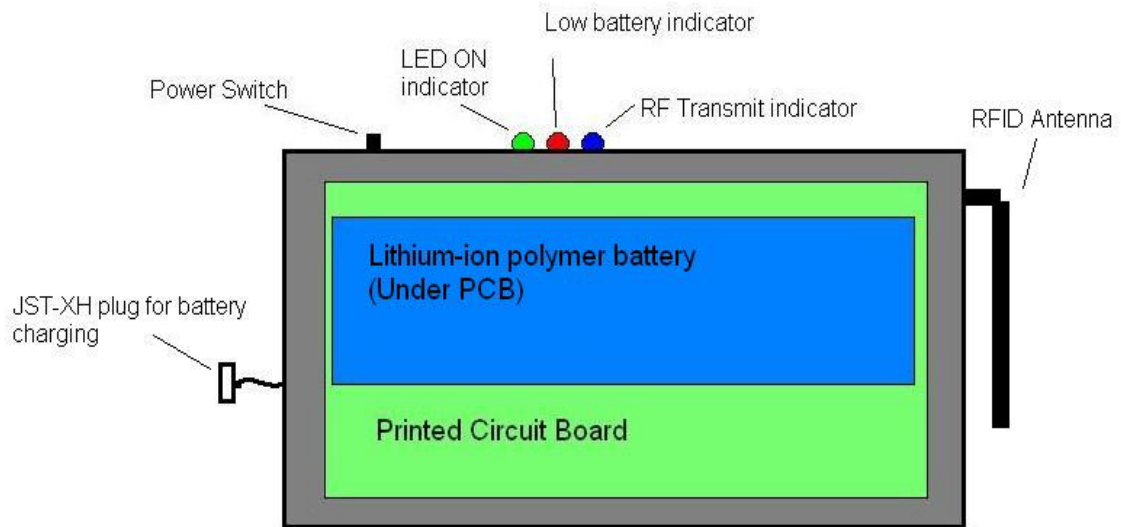

Figure 34 - Layout of parts within enclosure and location of external components

The goal will be to have everything fit into the case without much room around the edges for the board and battery to bounce around. We can add small pieces of foam in any areas where there are gaps between the PCB and the inside of the case. The foam will also help with any shock absorption if the reader unit is unintentionally dropped or knocked into something. Although the unit should not get too hot, we will take measurements during the testing phase. If needed, we can add ventilation holes on the back and sides of the case to keep the temperature inside as low as possible.

With all of the parts safely secured inside the plastic closure that last thing that needs to be added to the reader unit is a mount. Since the unit is meant to be mounted to a person, we need some way for the reader to attach comfortably. The easiest and probably most comfortable solution is for the user to attach the unit to their belt. Using a small piece of durable nylon fabric, we can create a belt loop on the back of the unit. The nylon can first be glued and then for added strength be screwed in to the back of the unit. The reader should then rest on the users belt loop in the orientation shown above in figure 39. This will allow the user access to view all of the LED indicators that are visible on the top of the reader unit. It will also give the user easy access to the ON-OFF switch which will be labeled with small stickers.

## 3.3 Microcontroller Design

### 3.3.1 Microcontroller Hardware

The microcontroller in the project's main purpose is to take in data from the reader IC, convert it to the proper protocol, then send it to the Xbee to be sent to the base unit. The microcontroller will also include two LED's to indicate when data has been sent or received.

Two LED's will be connected to digital output pins on the microcontroller for testing purposes. These pins will be in place on the final project to give a quick way to troubleshoot any problems that may be occurring. A green LED will blink whenever data is read in from the Reader IC. A red LED will blink whenever data is written to the Xbee. The handling of the blinking will be done by software on the microcontroller. The microcontroller will be connected serially to both the Reader IC and the Xbee. The baud rate for both of these should be at 9600 bps. Figure 35 shows how the connections will be made to the Xbee, Reader IC, and LED's.

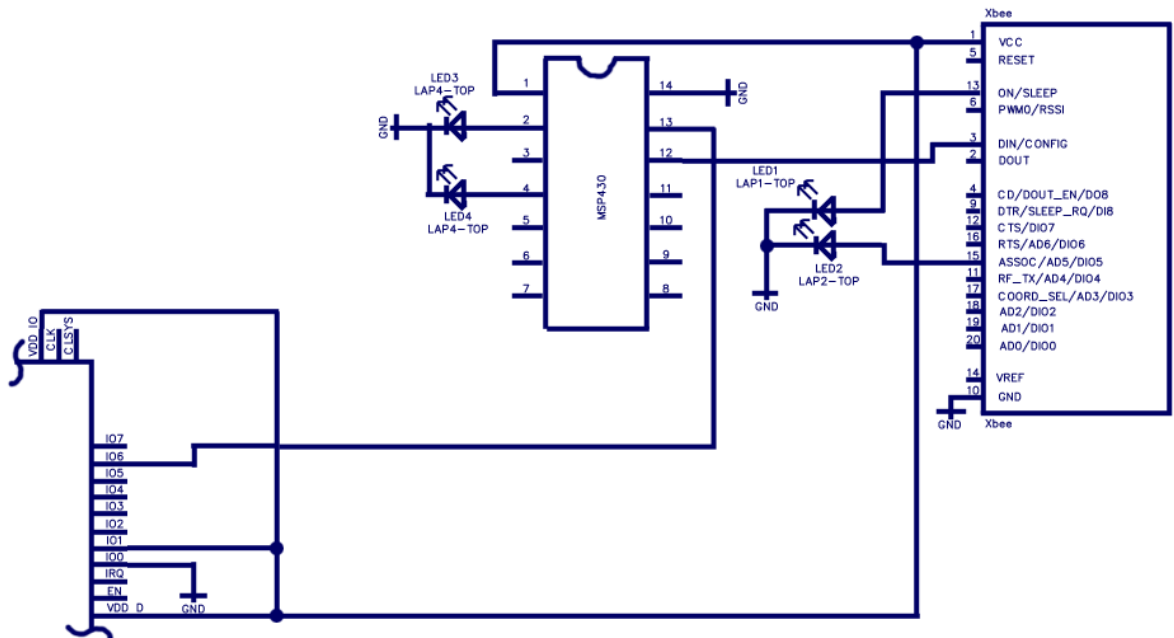

Figure 35 - Xbee/Reader layout



### 3.3.2 Microcontroller Software

The microcontroller in the reader will be used to take information reader in through the RFID chip, convert it to the proper data protocol and send it serially to the Xbee module. The software in the microcontroller will need to first setup the Xbee to communicate with the base module. After completing the setup process, the microcontroller will continue to monitor the RFID reader chip to check if any new data is available to receive. Once data is available to transfer, it will save it in a variable in its current format, convert it to the proper protocol, then send it serially to the Xbee module. The protocol chosen for this project will be a four digit ASCII number. The character that will indicate the end of the four digits will be the carriage return. The program will be written in a version of C for the RSP430. The functions needed to implement the program are as follows:

**void setup()** This function will set the PINS on the microcontroller to the proper state (Input/Output etc...) and set the baudrate. It will also call the setDestination and blink functions. It will run once on start up.

**void setDestination()** This function will set the address for itself and set up its destination address. It will also set the PAN ID to prevent any confusion if there are any other Xbees nearby. Finally, it will set the Xbee to data mode so communication is simplified.

**void blink(int count, int led)** This function will be to blink an LED attached to a digital output pin on the microcontroller. Its main purpose will be used as an indication that the setup function has been completed successfully, or to show when data is being transmitted. The led argument is used to indicate which pin is going to be "blinked."

**void loop()** This is the main function of the program. It will continually scan the input pin to see if any data is available to be read in. If it is, it will call the handleserial function. After the conversion is complete, the function will cast it to a char and send it serially to the Xbee module. This function will also monitor one of the digital pins that has been designated as the test pin. A button will be connected to the

**void handleserial()** This function will be called when data is available from the RFID chip. It will read in the data and check to make sure all of the values are valid ASCII numbers. This shouldn't be a problem with this project, but its being added as an additional safeguard. Since the carriage return is being used in the data protocol, sending this value at the wrong time can cause serious problems in the GUI.

**void test()** This function will send a preset series of number to the Xbee module at the base. It will be used during the testing phase to confirm the microcontroller and Xbee are functioning properly.

The following figure 36 outlines which functions are called by the various functions in the program.

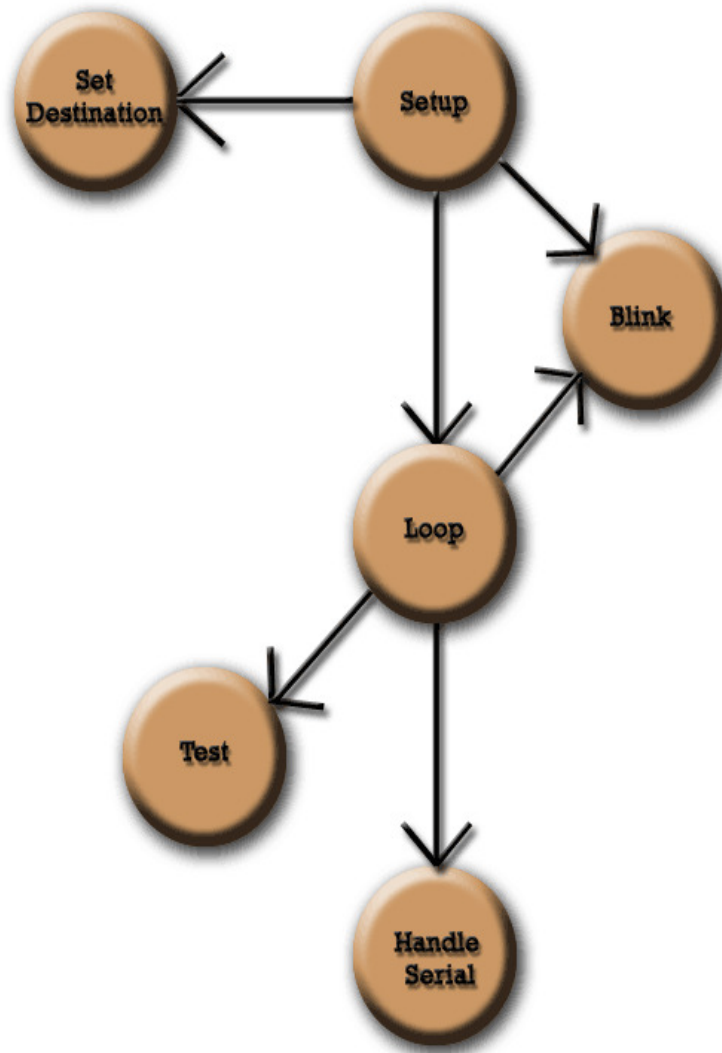

Figure 36 - Chart of function relations

## 3.4 Xbee Wireless Communication

### 3.4.1 Breakout Board

The Xbee module has 20 pins spaced 20mm apart. This size is too narrow to fit into a traditional breadboard. During the process of constructing the reader and base we'll want to be able to make measurements and test the setup prior to installing the Xbee onto a PCB. There are two options available to help in this. The first option is to just solder a wire to each pin to extend the legs. The other is to make a simple breakout board. It was decided that the breakout board would be the best choice.

The first step in making the breakout board was to layout a PCB. This PCB would ideally be about the same size as Xbee itself. If you notice in figure 37, the through holes for the Xbee are on the outside of the PCB. The middle two rows of holes are where the pins will go that will connect to the breadboard.

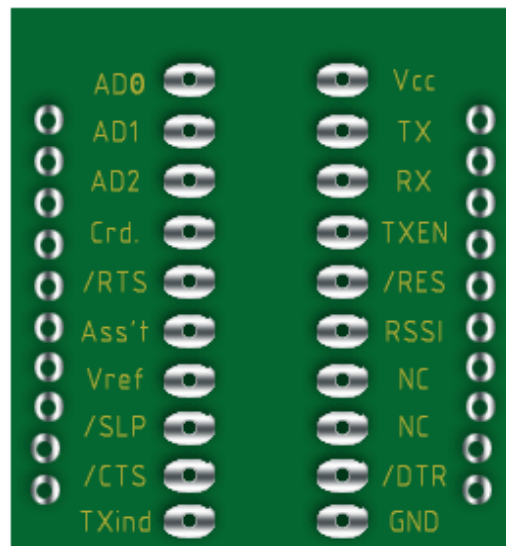

Figure 37 - Breakout board step one

After the PCB layout is done headers are soldered to the middle rows. These are the pins that will connect to the breadboard. This step is shown in figure 38.

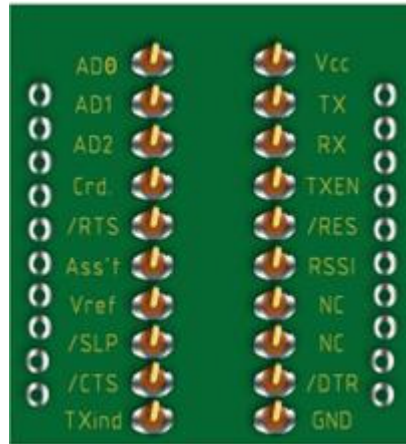

Figure 38 – Breakout board step 2

Finally, female sockets are installed on the outer rows. The Xbee will plug into these sockets. This final part is shown in figure 39.

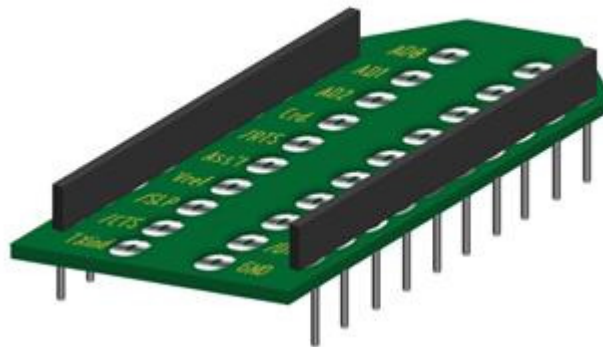

Figure 39 - Breakout board final step

### 3.4.2 RS-232 to USB Conversion

The Xbee module at the GUI will be powered by and communicate with the computer through a USB port. The Xbee module itself communicates in RS-232, so a method of conversion will be required. To accomplish this a conversion circuit will be used. For our project, we decided to use the MAX3323 for this task. This IC will work at the voltage range that we need, and is fairly simple to use. The IC has pins for RS-232 RX, RS-232 TX, TTL Tx, and TTL Rx. The schematic for the Xbee/MAX3323 layout is shown in figure 40.

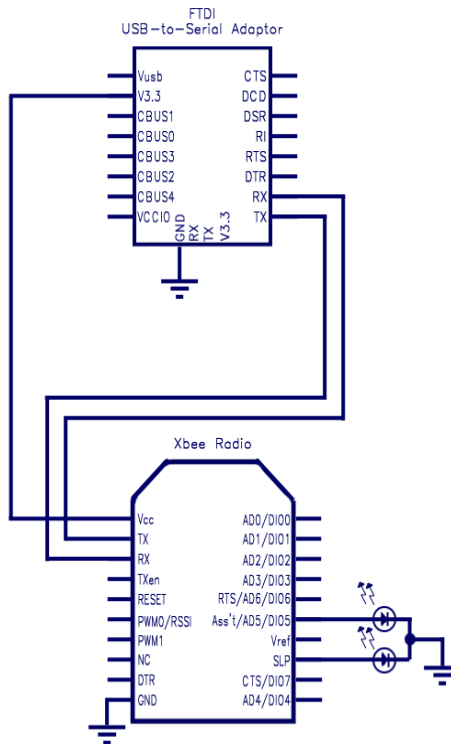

Figure 40 - Xbee/Max3323 layout

### 3.4.3 Xbee to Microcontroller Communication

The Xbee on the reader will be connected to a microcontroller. This microcontroller will take in data from the RFID IC and send it serially to the microcontroller. The microcontroller will then send the data out serially to the Xbee. The connection between the Xbee and the microcontroller is shown in figure 41.

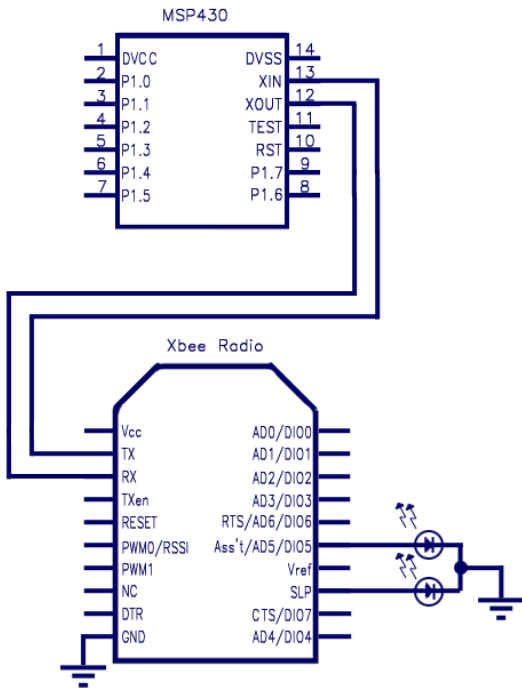

Figure 41 - Xbee/MSP430 layout.

### 3.5 GUI

The graphical user interface is designed to allow a non-technical user to utilize the tracking program. The user will start by uploading a map of the area that is to be tracked. This map will act simply as a 'wallpaper' to give a graphical representation of the readers position in relation to the grid of nodes that are laid out. After uploading the map file, the user will then place the positions of nodes on screen. The number of each tag will need to be inputted as part of this step.

After the initial setup of the graphic portion of the program is set by the user, the program will monitor the serial buffer for new data. If any is found it will update the readers position on the map. This process will happen on a continuous loop until the program is terminated. Since the objects – or people – we will be tracking with this project are moving rather slow, the speed at which this happens isn't a vital issue – through it is still desirable.

In addition to the visible features of the GUI, it will also initialize the Xbee radio module that is connected to the PC. In order for the Xbee to function properly, it must first have the baud rate, address, and destination set prior to use. When the GUI program is first started it will send these values to the transceiver.

The GUI program itself is coded in an object oriented fashion using JAVA. It was determined that eight classes would be needed to support all the functions that are required. These classes are listed below.

### 3.5.1 Tag Class

The tag class is used to hold information on all the tags that are needed in the program. The Tag class consists of the following members:

- **private int address** This variable holds the address of the tag.
- **private int xpos** This variable holds the x position value of tag.
- **private int ypos** This variable holds the y position value of the tag.
- **private int number** This variable holds the “number” of the tag.

The Tag class also contain the following methods:

- **public void setXpos(int pos)** This method sets the xpos data member to the value of pos.
- **public void setYpos(int pos)** This method sets the ypos data member to the value of pos.
- **public int getXpos()** This method returns the value of the xpos data member.
- **public int getYpos()** This method returns the value of the ypos data member.

In addition to these methods, the class also has a constructor:

- **Tag(int add, int xp, int yp)** These inputs correspond to the listed data members. The names were changed to avoid confusion.

## 3.5.2 Map Class

The map class holds the background art for the program. The map class consists of the following members:

- **private Graphic wallpaper** This object is a graphic file. It will be imported as part of a library.
- **private int xdim** This variable holds the length of the picture in the x dimension.
- **private int ydim** This variable holds the length of the picture in the y dimension

The map class also contains the following methods:

- **public void loadMap(Graphic map)** This method loads the map to be used as the background image.
- **public void setDim(int x, int y)** This method sets the dimensions of the map graphic.
- **public void draw()** This method draws the map graphic to the screen.

The map class also has a constructor to ensure all the necessary data to draw is available prior to calling. It is as follows:

- **Map(Graphic map, int x, int y)** These objects/variables are stored in the class's data members.

## 3.5.4 Radio Class

The radio class holds information on the wi-fi connection that is connected to the computer. The radio needs to have an address assigned when it's connected and have the address of the corresponding radio on the reader stored to function properly. The radio class has the following data members:

- **private int address** This holds the address of the radio.
- **private int baud** This holds the value of the baud rate of the serial port.



The radio class also has the following methods:

- **public void setAddress(int add)** This method sets the radio's address.
- **public void setBaud(int b)** This method sets the serial port's baud rate.
- **public void setup()** This method initializes the radio to start communicating on the network.

### 3.5.5 Taghit Class

The taghit class keeps track of hits that come through the wi-fi network. Since a tag hit is only processed once, there aren't any methods to change the instance variables. These will be set with the constructor when a hit is detected. The taghit class contains the following members:

- **private int time** This member contains the time of the hit
- **private int address** This member contains the address of the tag that was detected

The taghit class also contains the following methods:

- **public int getTime()** This method returns the value of the time variable.
- **public int getAddress()** This method returns the value of the address variable.

The constructor is as follows:

- **Taghit(int time, int address)** This constructor simply sets the instance variables.

### 3.5.6 Location Class

The location class is used to display the location of the mobile reader in the GUI. The location will be indicated by a graphic that is overlaid on the background map image. The location class has the following data members:

- **private mark Graphic** This object will be imported from a library. It will be used to store the graphic that will be displayed on the GUI to indicate where the reader is.
- **private int xpos** This variable will store the x position of the reader.
- **private int ypos** This variable will store the y position of the reader.

The Location class also contains the following methods:

- **public Graphic getPic()** This method returns the graphic object data member.
- **public int getYpos()** This method returns the value of the ypos data member.
- **public int getXpos()** This method returns the value of the xpos data member.
- **public void setGraphic(Graphic pic)** This method sets the Graphic object data member.
- **public void setXpos(int x)** This method sets or updates the x data member.
- **public void setYpos(int y)** This method sets or updates the y data member.

The location class contains the following constructors:

- **Location(Graphic pic)** This constructor sets the Graphic object data member. The x and y data members are set to a default value.
- **Location(Graphic pic, int y, int x)** This constructor sets the value for all the data members.

### 3.5.7 Calc Class

The Calc class is used to determine the location of the reader based on recent tag hits. The class will consist of class methods as it is intended to be used globally. The class contains the following methods:

- **static public updateLocation()** This method updates the location of the mobile reader. The data needed to accomplish this are static members of the GUI class, so no arguments or return values are needed.

### 3.5.8 Reader Class

The Reader class is used to take in data from the serial buffer and convert it into a taghit object. Since there may be many sets of data waiting in the serial buffer, the Reader will run on a loop until the buffer is empty. To prevent a deadlock in a data rich environment, a loop counter can be used to set a maximum number of times to read in data. The class contains the following data members:

- **private int time** This data member holds the current time.
- **private int address** This data member holds the address of the tag that was hit.

The class also contains the following methods:

- **public void getData()** This method will check the serial buffer and continue to loop until all the buffer is empty.
- **public void getData(int count)** This method will check the serial buffer and keep checking until the number of iterations in the argument has been met.
- **private void addTag(int time, int address)** This method adds a new tag to the active tag list.

### 3.5.9 GUI Class

The GUI class is the main component of the program. It will continually monitor for new hits, get rid of old ones, and update the position on the screen. The class also keeps track of the art needed for the user to visualize the readers position and control how it's displayed. The GUI class contains the following data members:

- **private Map background** This object is used to display the background art for the program.
- **private JFrame frame** This object is used to display the frame for the program.
- **private JButton addMap** This object can be utilized to add a new map by the user.
- **private JButton addNode** This object can be utilized to add a new node to the map.

- **private JButton start** This object is used to start the program after a map and nodes are added.
- **public static PriorityQueue<Taghit> queue** This list will hold all of the recent hits the mobile reader has received. It will be prioritized by order of oldest first. This will speed the process of checking through the hits for old values.
- **public static Reader reader** This object will handle the reading of the serial buffer when an update is required.
- **public static Location location** This object will store all of the information needed to determine where the mobile reader currently is.

The class also contains the following methods:

- **public void initialize()** This method will be called first in the program. It will wait until the user has entered a map and all of the nodes. It will return from the method once the user has selected the start button.
- **public void update()** This method will continue to loop while the program is active. It will check for new entries and delete ones that have been deemed to be “old” (except for the very last one). It will also organize the drawing and the location of the mobile reader on the map.
- **public void draw()** This method will handle the drawing of the location on the GUI.

Figure 42 summarizes how the GUI is constructed and its relation to all of the other classes in the program. The program was designed to be expanded if needed during later phases of the project. At present the only classes that are used to create more than one object are the Taghit and Tag classes.

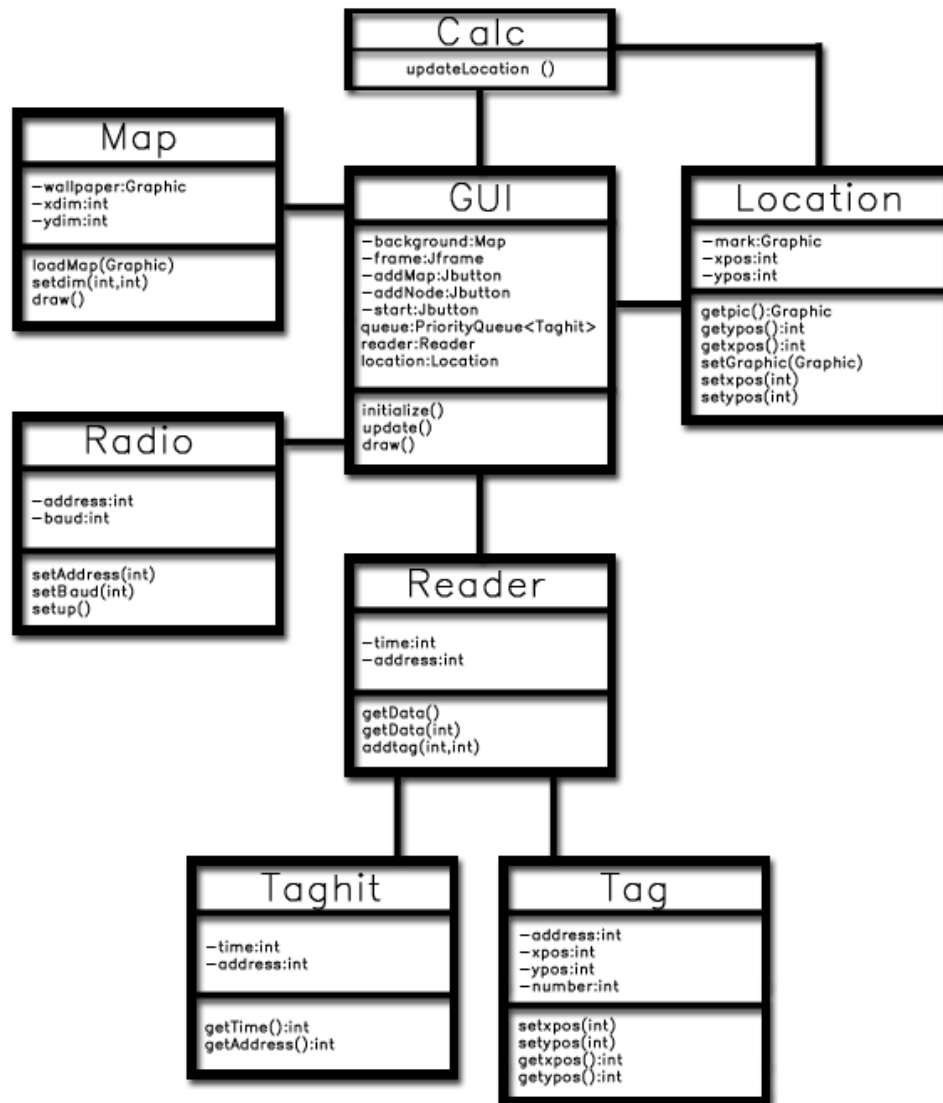

Figure 42 - UML diagram of the GUI program.

### 3.6 PCB Layout and Design

Eagle Layout Editor 5.11.0 from Cadsoft was used to lay out the entire reader circuit schematic, and to transfer it to a PCB layout. Many of the circuit components used in this design were standard to the Eagle library. One of the

challenges of the PCB design was creating custom devices, schematics and packages for the less common ICs and components, such as, the AS3992 IC, SFM switch, transformers, etc. Creating custom components allows for a greater chance of error. The group is confident that the package footprint of each custom component matches exactly the footprint of the actual IC or component to be used.

The PCB file created in Eagle will be sent to International Circuits. International Circuits is located in Natick, MA, and their standards are compliant with US FCC IPC Class II standards. They have agreed to review the file, make any necessary changes to optimize the layout, and send it back for final approval. Once the final layout is approved, International Circuits will print and ship the circuit board. The cost for optimizing the layout, printing and shipping is \$53.00. The dimensions of the PCB are 3.5 X 2.8 inches. The board is 2 layers with milled edges. The material is FR4 Dielectric DE117. The thickness of the board is 0.51 mm. Figure 43 gives the PCB layer properties.

<b>Material</b>	<b>Thickness (µm)</b>	<b>Layer Name</b>	<b>Comments</b>
Copper Plated	36	Top	Top side Layer 1
Pre Preg	500		DE117 Dielectric constant 4,7
Copper Plated	36	Bottom	Bottom side Layer 4

Figure 43 - PCB layer Properties

Once the schematic layout of the reader was completed, the PCB layout tool was used to place each component and connecting traces. Figure 44 shows the PCB layout.

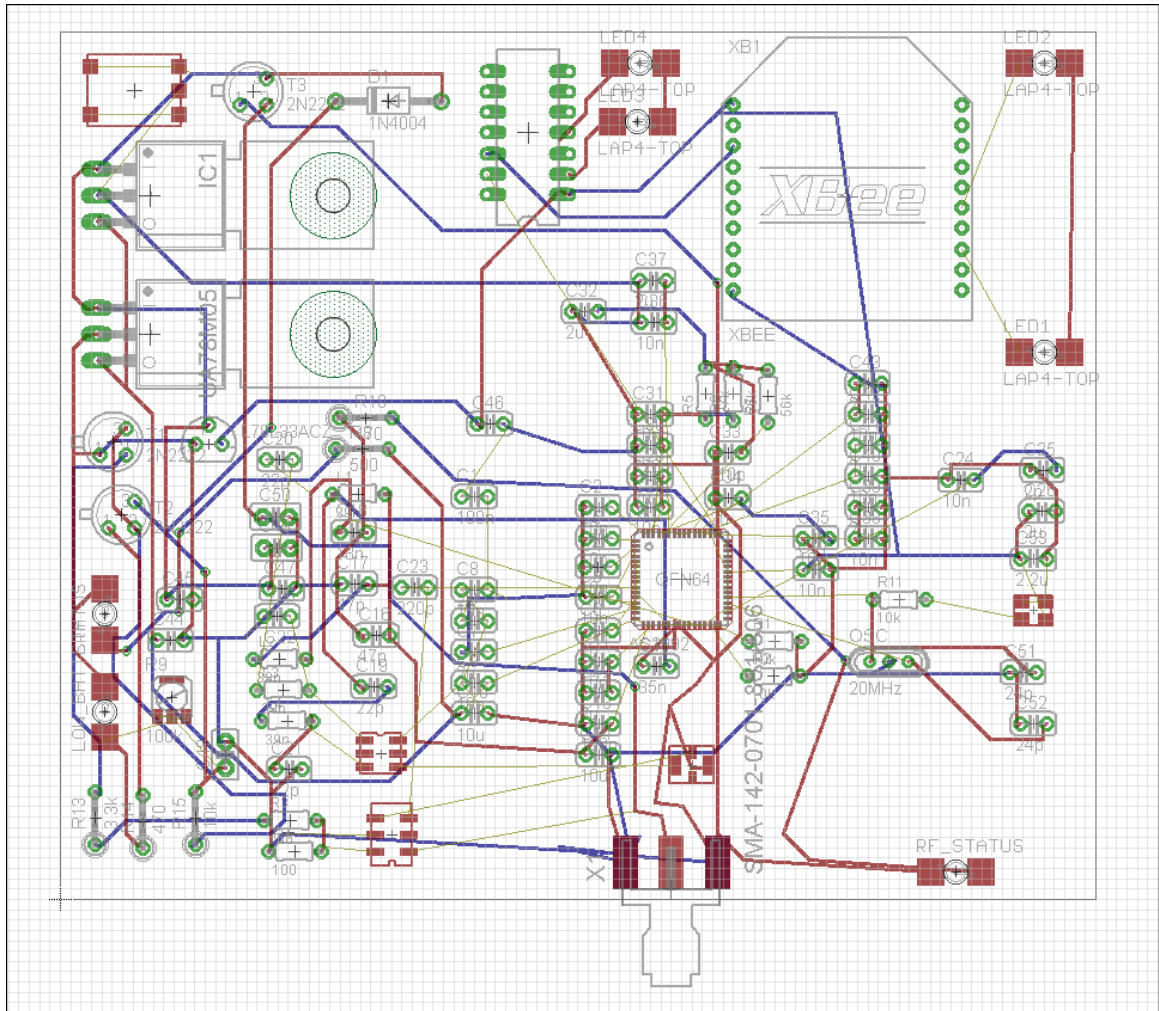

Figure 44 – PCB Layout

## 4.0 Design Summary

### 4.1 Hardware Design Summary

This section will present a summary of the hardware design. The major components that comprise the reader system are the UHF RFID IC, microcontroller, RF transmitter, crystal oscillator, filters, couplers, and battery. Figure 45 shows the schematic layout of the entire reader IC and how the system is wired together. The following sections will summarize the design of each of these components.

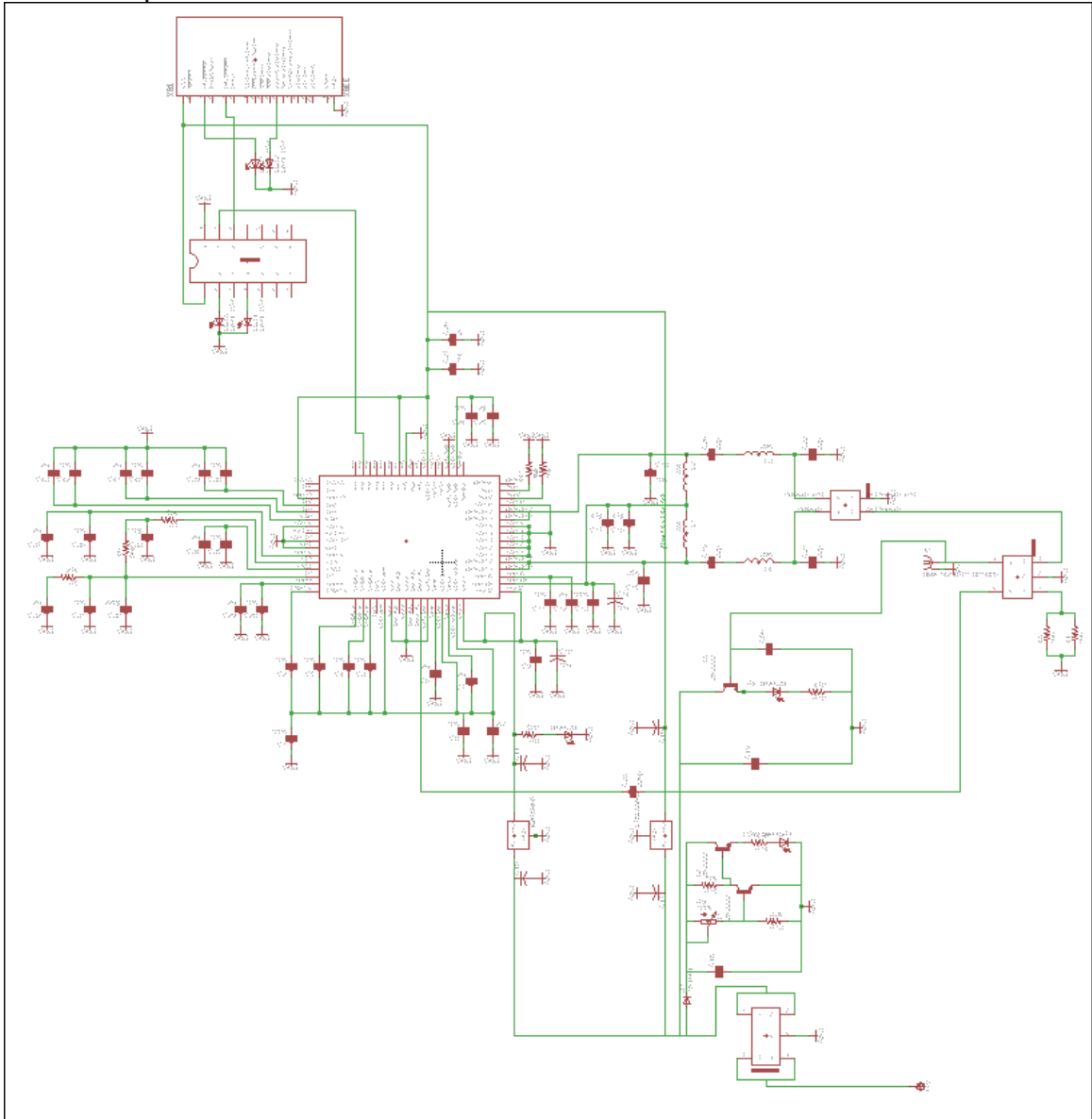

Figure 45 – Complete Reader Schematic



### 4.1.1 Power and Indicators

The power requirements of our reader unit are an important subject. After doing research on batteries we came up with a 7.4 volt lithium-ion polymer battery with a capacity of 2200 mAh. The battery will be connected to the PCB board and the power will then be distributed through 2 different voltage regulators. The first voltage regulator will output 5 volts and 500mA and will power the reader chip and our green LED on indicator. The second voltage regulator will power the Xbee wireless module and will output 3.3 volts and 100mA.

Tied into the power circuitry are two additional LED indicators. There is a red LED indicator that will light when the voltage in the battery falls to 7.0 volts. There is a potentiometer connected to this circuit that can be used to vary the level at which the low battery indicator comes in.

The second LED indicator in the circuit will light a blue LED when the reader chip transmits RF energy. The circuit is powered by a single 2N2222 transistor and uses the RF output from the reader chip as an input. This indicator will not however show when the Xbee wireless module is transmitting RF energy, which we expect to be more frequently.

### 4.1.2 Reader

The reader will follow a reader talk first protocol when communicating with the tags. It will send out an interrogation pulse and wait for a backscattered signal from the tags. The reader will use an ASK modulation and demodulation when communicating information to and from the tags. The carrier frequency will be set to 915MHz. All signal processing will be handled by internal reader components. The reader will operate as a slave to the microcontroller. Once the battery switch is closed, the reader will receive 5 V regulated into the VEXT pin. This input will power all of the internal regulators and distribute power throughout the chip. Once the chip is fully powered, and oscillators are stabilized, the reader waits for a command from the microcontroller.

An external crystal oscillator will be used as a reference. A TCXO will be used for increased accuracy. This is recommended for the AS3992 manufacture. A matching network with a balun filter is used to match input and output impedances. A 50 ohm SMA dipole antenna is connected to maximize read range. An SMA female PC mount is used to connect the antenna to the transmit and receive paths of the reader. A low pass filter is connected to the antenna to filter out the second and higher harmonics. A directional coupler is used in the output stage to separate and isolate the transmit and receive signals.

## 4.2 Software Design Summary

### 4.2.1 GUI

The GUI will be coded in the programming language JAVA. While JAVA does suffer from some overhead issues when dealing with some programs, the needed run time speed for this project was rather low. The benefits that JAVA brings with the large number of libraries and ease of use made it the obvious choice for us.

The GUI program will initially appear with a blank screen with three buttons – Add map, Add node, and Start. The user will first select the Add map button. This will bring up a box to select the graphic file the use wants to use for their back ground map.

After selecting the map, the user will select the Add node button. This will bring up a box to enter the address of the tag they want to add to the map. After entering the address, the box will disappear and a black circle will appear on the user's cursor. The user can now simply click on any part of the map to indicate where that particular node is located. This process continues until the user has added all the tags.

The final step will be to simply select the start button. The figure 46 below outlines this process.

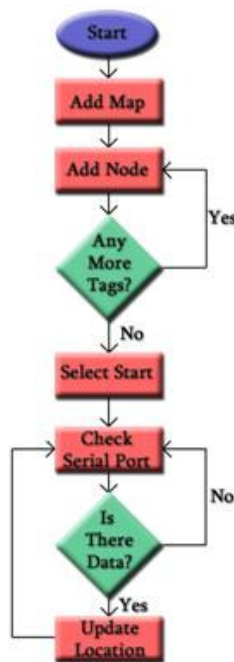

Figure 46 - Flow chart for the GUI

In addition to all of the visual aspects of the program, the GUI will also be responsible for initializing the Xbee module that is connected to the computer. It will set both the address for the base Xbee as well as the target address as well as the baud rate. This information must be completed every time the program is used, so the GUI seemed like the best place for this to take place.

## 4.2.2 Microcontroller

The microcontroller code will be done in a C type compiler provided by Texas Instruments. The main purpose of this microcontroller is to take in serial data from the reader IC we are using for the RFID detection. The microcontroller will continue to monitor the serial port of the reader IC and bring it in when available.

Once this data has been received it will convert it to the data protocol we are using. The protocol we selected is a four digit ASCII number followed by a carriage return. After this conversion has been completed, it will send it to the Xbee for transmission to the base.

In addition to this vital role, the microcontroller will also be used to initialize the other components on the board. The IC used for the RFID reader has a default mode that is not quite what we want to use for this project. The microcontroller will make the appropriate setting changes upon start up so it will better suit our needs. The Xbee will have it's address initialized as well as the target address set to the Xbee at the base unit.

The following figure 47 demonstrates the basic outline of how the microcontroller code will function in the project.

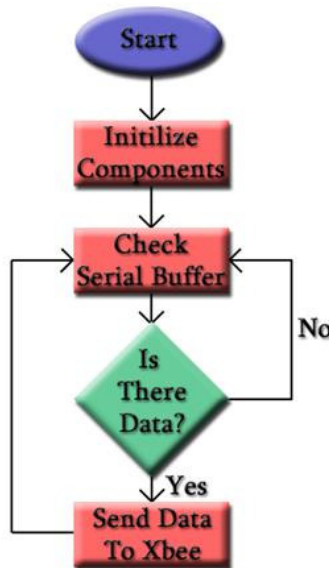

Figure 47 - Microcontroller flow chart.

## 5.0 Prototyping and Testing

### 5.1 Prototyping

Prototyping the reader unit we probably be one of our most difficult tasks. The first step of prototyping will be to assemble all of our parts on a breadboard. For the power components and the Xbee module this will not be too difficult, but for the austriamicrosystems reader IC, this will be a challenge. The reader IC comes in a QFN package meant to be directly surface mounted to a printed circuit board. Since we need to come up with a working prototype on a bread board first, we will need to find a solution.

The first and most simple solution is to purchase a development board that austriamicrosystems sells specifically for this chip. The company sells several boards with varying levels of interface and features. The two boards that we will consider for our project are the “LEO” evaluation board and the “micro” evaluation board.

The LEO evaluation board is powered straight from a USB port. The board is capable of both reading and writing to UHF RFID tags. There is a built in 8-bit microcontroller with software that has been written in C for easy porting. The board has through holes for easy connection to certain pins of the microcontroller that can be used to control the reader IC.

The next evaluation kit we looked at from austriamicrosystems is the AS3992 micro kit. The board has some nice features such as, like the LEO, it is powered entirely off of USB. It also comes with a GUI that you can use to change settings on the reader unit. The GUI allows you to change things like the output power, the receive sensitivity, change frequency schemes, and edit settings in any of the registers of the chip. One drawback is that the development board is very small and seems to lack a lot of useful features. There are no through holes to connect to and unlike the LEO board, there is no microcontroller on the board.

Although either of the development boards from austriamicrosystems would probably benefit us the most in the development of the entire project, the cost of the board might be a large deterrent. The LEO board is priced on the company’s website at \$500 and the micro chip is priced at \$299. This would take up a lot of our budget and is not the most cost effective solution. We would also still need to but a second and even possibly third reader IC to use for our actual project.

The second choice, which is what we are planning to use, is a QFN adapter. With this simple piece of hardware, you are able to attach the chip to the small printed circuit board, and have pin outs to all of the pins that we would need. The cost of this board is significantly less at \$4.50. The adapter is compatible with many different chip packages and can handle between 16 and 80 pin chips.

Although the adapter is much cheaper than the development board, we would still need to purchase a reader chip to use solely with the adapter and for prototyping purposes. This option is still around 3 times cheaper than the development board. With this we will now be able to connect all of the components on a breadboard.

Our first goal will be to connect everything on the breadboard according to our circuit diagrams. To begin we can simply use a DC power supply like the one in the senior design lab. After connecting everything to the breadboard and testing to see that all of the components are receiving power, we can begin initial testing to make sure the device works as we want it to. By using the breadboard, we will be able to make quick changes to our design if something is not working as planned.

After getting a fully working prototype on the breadboard, we will be able to make any needed changes to our printed circuit board layout design. If all goes well the first board that we make utilizing the printed circuit board will work as planned, otherwise we will need to troubleshoot and make the necessary changes to the board.

## 5.2 Building

Once we have a working prototype on the bread board we can begin the build process. We will make any changes that need to be made to our printed circuit board layout design and order the board. We will then need to attach all of our parts to the board. We will take the board to the radio club in order to mount all of the surface mount components to be sure they are attached correctly. For the rest of the parts we will solder them to the board ourselves. Once we have the circuit board complete, we can start putting all of the components into the ABS plastic enclosure. We will need to drill the holes for the three LED indicators, battery charge plug, power switch, and antenna connection. The next step will be to put the battery in the bottom of the case, attach it to the circuit board, and then place the board on top of the battery. We will place a thin piece of foam between the battery and circuit board and then in any other places where there are gaps between the board and the side of the case.

## 5.3 Testing

### 5.3.1 Tags

Testing of the tags is vital to the overall success and accuracy of the project. The testing of the tags should be extensive and not easily overlooked. Different locations of the tags and different materials in the room can have a large effect on the tags performance.

The first aspect we will need to test is the tags range. At the initial stages we will test only the tag inlay without it being attached to any type of backing. We will do this by powering on the reader unit and starting with the tag inlay at a distance that we expect will be out of the range of the reader, such as 30 feet. The tag will be fixed and we will move the reader progressively closer to the tag. At some point as we are getting closer to the fixed tag, the reader should come within range of the tag and pick it up. We can then use a tape measure to get the read distance of the tag. We should repeat this procedure a half dozen times so that we can get an average of the read distance.

Since the tags are very sensitive we will need to repeat the procedure listed above several different times after changing small variables. The first of these variables should be tag orientation. Since the orientation of the tag can play a big role on the actual read range we should test any possible orientation the tag. The first orientation we will test is the one that the tag is primarily designed for and that is the top or front side facing the reader. We will then proceed with the distance test explained before. We will then need to test orientation such as the tag being flat, with its smallest edge facing the reader, upside down, and even at a variety of random angles. Each time we will conduct the same test of starting with the tag 30 feet away and slowly moving toward it.

Once we have done all of the testing with tag orientation and determined the best positioning of the tag, we can move on to testing the tag on various materials. The type of material the tag is affixed to or set on can also have a large distance on read range. Since most of the tags will be attached to something concrete, such as the floor, this should be the first test. After attaching the tag to a wall with some tape, we will again go through the test procedures stated before. After this we should find a metal door to test if the door has any advantage or disadvantage in range.

Once we have determined an orientation and surface to place the tags on, we can confirm that our choice of backing for the tags works. We will of course check our design choice of a light cardboard first. Running through the same test as before, we can determine if the light cardboard will suit our needs. If we do not like the results we can try some of our secondary choices such as the plastic or lamination.

The last thing we need to test with the tags is how they will react with other objects in a room. Since our project should be used to track someone in any building, objects such as furniture and other people shouldn't have an impact on accuracy and results. We should make sure to test the tags around all types of furniture, metal, wooden, and a mixture of the two. We should also make sure to test with other computers and electronic equipment in the room since these are the conditions the system will actually be used in. Lastly we should make sure the tags communication is not interrupted by people. We can test this by having one or more people stand in between the tag and the reader and make sure there is little or no effect.

After doing all of this testing we should then have clear data on the read range of the tags under the situations we plan on using them for. With this data we can modify, if needed, our original design for the grid of tags. Knowing how, if it all, people and furniture can affect the tags, we can place more tags in certain places in the room, or less if needed.

## 5.3.2 Battery and Power

Testing of the battery and power system of the reader will be important for us to make sure it meets our expected specifications. The first component we should test is the battery. After following the instructions supplied with the charger from sparkfun.com, we first need to fully charge both of our lithium polymer batteries. We can then connect a load to them that will approximate the load that our completed reader will be, around 500mA at the supplied 7.4 volts. We need to let time take its course and see exactly how long the batteries last for before they are too weak to power the circuit.

After testing the batteries the next step will be to test the rest of the power circuitry, the two voltage regulators. To begin with we will connect a DC power supply from the senior design lab to the regulators, first individually. After varying the voltage from the supply through the low and high voltages we might expect from the battery, we will then connect the regulators in parallel, how they will be in the actual project. We can now run the same test insuring that the regulators perform as expected at the voltages we can expect to see from our lithium polymer battery.

### 5.3.2.1 Indicators

It will also be important to test the various LED indicators on the reader unit. The ON indicator doesn't require a large amount of testing because it will simply come on when the reader is powered on and enough voltage is being applied to ensure the voltage regulator is supplying the correct voltage. The LED that will need to be tested for correct operation is the low battery LED.

#### 5.3.2.1.1 Low Battery Indicator

For this we should again use the DC power supply so that we can trigger the LED to turn on when we want it to. After some initial testing of the reader we can then determine an exact voltage that we want the low battery LED to come on at. Once we have determined this, we will use the DC voltage supply to power the reader unit. We can then adjust the potentiometer in the low battery circuit until we find the correct setting. We should then use the actual battery to make sure that all of the results of testing done with the power supply match those with the lithium-ion battery attached.

### 5.3.2.1.2 RF Transmit Indicator

It will be important to make sure that the LED indicator for the RF transmit is working properly as we will most likely use this indicator during other testing of the unit. To properly test this, we will need to make sure that the Xbee wireless module is not transmitting and is powered off. Then by using a meter that checks for RF transmission we can power on the reader IC. We will verify with the meter that the unit is actually transmitting RF and check to ensure the LED is lit. Once we are satisfied with our test we can re-connect the Xbee and proceed with the resting of the testing.

### 5.3.3 Reader Microcontroller

The MSP430 microcontroller used in this project will be programmed by software provided by TI. This software is a basic C type language. The program itself will be loaded onto the microcontroller by using the launch pad development board – also provided to us by TI.

The first step in the prototyping process is to program the MSP430 using the launchpad. After this step has been completed removed it and place it onto a breadboard. Since we'll want to use a USB connection to the computer we'll be using an RS232 to USB conversion IC to make the process a bit easier. SparkFun makes an inexpensive board called PCB-BOB-00718. We'll be using this board for testing throughout the project. For now, place the conversion board on the breadboard and connect it to the microcontroller in the method shown in figure 48.



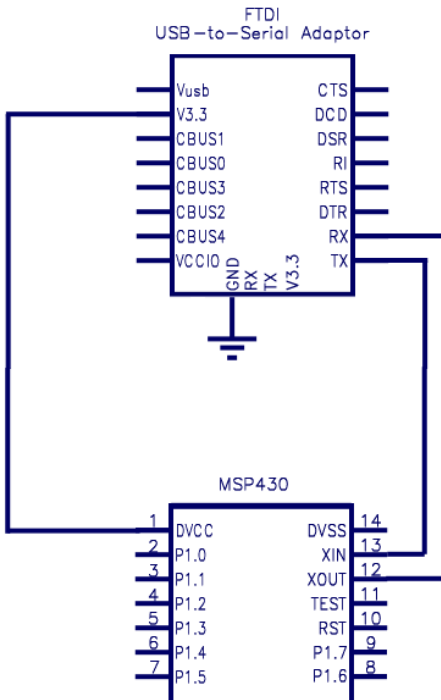

Figure 48 - MSP430/Bob layout

To assist in the testing process a short program was written to help organize the input. With the protocol we are using the carriage return indicates the end of a stream of data. The program will pull the data in and add a new line feed. It will also delete the top line of the input if there are a large number of strings sent. This will enable the screen to scroll down as new data comes in. The following functions are used in the program.

**void setup()** This function will detect which port the unit is connected to and handle setting up the basic look of the window used for the program – size, font etc...

**void draw()** This function handles how the data is printed on the screen

**void serialEvent(Serial myport)** This function will detect when a new string of data is available on the serial port for the unit. It will also keep track of the line count and call the deleteFirstline() function when necessary.

**void deleteFirstline()** Deletes the first line in the string.

After properly connecting the unit together and plugging it into the USB. Turn the unit on. The power LED should now be on. The next step is to run the test

program previously mentioned on the PC. Wait until the program states “ready” before proceeding to the next step. The final step is to press the test button connected to the MSP430 and watch the screen for the following series of numbers

1. 1234
2. 4321
3. 5555

The data LED on the MSP430 should also flash when the button is pressed.

To summarize the process the following checklist should be used.

1. Connect the MSP430 and RS232 to USB conversion board according to the diagram.
2. Turn on the unit.
3. Check to make sure the power LED is on.
4. Start up the testing program on the PC.
5. Wait until it says “ready”.
6. Press the test button.
7. Check that the transmit data LED blinked.
8. Compare the results on the screen with the expected data.

After completing all of these steps, it is confirmed that the microcontroller and program are functioning properly.

### 5.3.4 Xbee Communication

The testing of the Xbee transceiver begins with ensuring two modules are able to communicate with each other and the PC before placing them into the project. This basic consists of first wiring of the Xbee module that will be at the PC and connecting it to the RS232-USB converter. This is then plugged into the USB port. The second module is connected to the MSP430 along with a button on pin 5. When the button is pressed, the microcontroller will send a set of values to the Xbee module to broadcast. The module at the base should read this and be read in by the PC. Any common serial terminal program can be used to see the values that are coming through the serial buffer, but when Xbee ends a transmission it only includes a carriage return but no new line feed. This results in the new information overwriting the old. To solve this problem a short program is written in C that will place the new line feed to make the data easier to read. The specific testing steps are outlined below.

The first step in the setup process is to construct the breakout board for the Xbee module. The specific instructions for this are outlined in the design section for the Xbee module. To summarize the steps are:

1. Printed PCB board
2. Solder in pins for the breadboard
3. Solder in female sockets for the Xbee to connect to.

After constructing the breakout boards, we will connect the Xbee modules to them and the breakout boards to two breadboards. For the module at the PC, the RS232 to USB converter IC will also need to be on the breadboard. To simplify this part, a breakout board for the converter is also used. In this case an inexpensive board from SparkFun called PCB-BOB-00718 will be purchased. Connect the module to the IC using the diagram in the design section.

The module on the reader will have the Xbee and the MSP430 on the breadboard. The schematic for this is also in the design portion of the report. After physically setting these two portions up and carefully confirming that all the wires are connected to the correct pins, both modules are turned on. At this point the program that was written to help with testing is started. This program is written in C and consists of the following functions.

- **void setup()** This function handles the initial setup of the Xbee that's located at the PC, setting the size of the window for the user to view on their monitor and locates the serial address for the USB port the unit is plugged into. In addition it handles minor things like setting the font that will be used in the display.
- **void draw()** This function handles the drawing of the data to the screen. It organizes the strings of data and makes sure they are on their own lines.
- **void serialEvent(Serial myport)** This function is called whenever there is new data on the serial buffer. In the protocol chosen for this project, the carriage return was chosen to indicate the end of a transmission. Since we also want a new line this function adds the line feed and increments the line count. When the line count reaches a level that would be off the screen, the function also calls the deleteFirstLine() function. This lets the text scroll rather than try to print to a location outside the size of the program's box.

With the number of transmissions used for our testing, this shouldn't be reached, but we wanted to include this now encase a larger data set is later needed to confirm the Xbee is functioning properly.

- **void deleteFirstLine()** This function deletes the first line in the string that is printed to the screen.

The program for testing the Xbee module on the reader is already included as part of the overall program. There is a test function included that will be called when pin 5 goes high. This function will transmit the following sets of digits:

1. 1234
2. 4321
3. 5555

In addition to the data being sent, the Xbee modules and MSP430 also contain LEDs to indicate certain conditions. The “13” pins on the Xbee will should turn on and stay lit when modules are on. This confirms the power to the module is setup correctly. The “15” pins will blink when they are associated with another radio. This indicates that the setup routines in both the microcontroller and the test program have at least partially been completed correctly – it confirms the address and destination are correct on both. The LED on pin 4 of the microcontroller will blink whenever it is transmitting data to the Xbee. This should happen when the button connected to pin 5 is depressed and the test function is called. The following checklist summarizes the entire process.

1. Connect the Xbee and Converter to the breadboard.
2. Connect the breadboard to the computer by the USB port.
3. Turn on the unit.
4. Check to make sure the power LED is lit.
5. Start up the test program.
6. Connect the microcontroller and Xbee to the second breadboard.
7. Connect the unit to the power source.
8. Turn on the unit.
9. Check to make sure the LED power light is on.
10. Check to make sure the association LED on both units is now flashing.
11. Depress the test button.
12. Check the output on the monitor and compare it to the expected results.

After getting through the setup and initial test phase, the next step is to confirm the range on the two units. Many things in our environment can interfere with the signals given off by these transceivers. Some of the most common in the range we'll be using are: 802.11b and 802.11g wireless devices, blue tooth devices, baby monitors, cordless telephones, video senders, and microwave ovens. Since our testing will take place on one of the largest college campuses in the U.S. - and in close vicinity of many of tabs - the amount of possible sources of interference could be substantial.

The first step in testing the range is in very close proximity to each. The initial setup should be done at this range. From this point continue to move farther away at about 5 foot increments. At each step, press the test button to confirm it is working at this range. This should be done until all the corners of the room are confirmed to function properly.

After confirming that the range itself works, go to portions of the room that contain objects that could possibly interfere with the radio signals. Things like chairs (with metal legs), computers, wall outlets etc...should be the main focus. The area around any pillars in the room should also be tested as they may contain large amounts of metal.

Once the Xbees have been confirmed to work properly, its safe to place them into the final project. The GUI will reserve the specific values transmitted by the test function in the microcontroller to be used in testing.

If any problems are encountered during the use of the final product, an easier method is made available. Start by bringing up the GUI and adding the map. Next add three nodes and assign the addresses that are transmitted by the reader unit. Finally, press the test button on the reader unit and check the GUI. The location of the "tags" reserved for these values should be in a triangle formation. The estimated location for the test should be in the center of the screen. It's important to note that this method assumes that the GUI is functioning properly and should only used after fully testing that portion. This part is intended only as a quick test to see if there might be a problem with one of the transceivers.

### 5.3.5 GUI

The testing of the GUI is done in five stages. The first step is to verify the basic functions of the program are functioning correctly. This includes things like buttons and graphics. Since the GUI relies on layering the various graphics, close inspection is needed to confirm buttons don't end up hidden and interfere with the adding of nodes. The second step is to verify the radio is being setup correctly. This step is rather small, and is helped by the addition of an LED on the radio. The next step is to confirm that GUI is receiving the correct information from the reader unit. Functions in the microcontroller have been written to assist with this step. The third step is confirm the GUI is calculating the correct position. The system that we are using does not account for signal strength. While the reader does have the ability to get that information, the reliability of it when determining specific position is suspect. Various items and signals can impact the value that come through. The final step is to verify the system is tracking correctly. This is actually the most complicated part of the GUI, so special attention should be paid to the results that are displayed on the screen. The reader can detect a "hit" from tags that are quite a bit outside the cluster of nodes it's currently residing in. The outliers should be eliminated with the algorithm we are using, but the data should be checked closely.

#### **Step One:**

The user should start by starting the program through it's executable file. After the program comes up, there should be three buttons: Add map, Add node, and Start.

Begin by selection the Add map button. When selected, this button should bring up a box where the user will select the graphic file they wish to use for the background image. Select the appropriate file and confirm this graphic is now displayed in the program box. Make sure to check if the image is behind the other two buttons. Upon successfully selecting the map, the Add map button should disappear.

After verifying the map button functions properly, the next step is to add some nodes. Start by selecting the Add node button. This should bring up a box to enter the address of that particular tag. Enter the number 0001 – note, be sure not to select the addresses 1234, 4321, or 5555, these are reserved for testing of the reader. After entering in the address, the cursor will change to a small black circle. Select a location on the map for the position of this node. For this phase of the testing, the location isn't that important. Continue adding nodes until you've reached five (0005). Scroll over all five of the nodes of the map and confirm they are the addresses you entered.

Once you have added the map and selected the five nodes select the start button. This should make the remaining two buttons disappear and a green icon will appear at the top right of the GUI to indicate the setup has been successful.

To summarize step one, use the following checklist:

1. Start the program.
2. Verify three buttons are present.
3. Select the Add map button.
4. Verify a box pops up to select a graphic file on the PC.
5. Select the graphic you wish to use for the background.
6. Verify the graphic selected shows up behind the remaining two buttons.
7. Select the add node button.
8. Verify a box comes up that prompts you to end the address of a tag.
9. Enter 0001.
10. Verify the cursor turns into a small black circle.
11. Select a spot on the map for the tag.
12. Repeat steps 9 through 11 until 5 tags are added.
13. Select the start button.
14. Verify all the buttons are now gone and a green icon is present at the top right of the GUI.

## **Step Two:**

In addition to the visual features of the GUI the program also initializes the radio that will be connected to the PC. The Xbee radio needs to have it's baud rate, address, and destination address set in order for it to function properly. A start up, the GUI will set all three of these automatically. The Xbee has an LED attached that will blink when it has sensed the Xbee on the reader.

The first step in this process is to ensure the reader's Xbee is functioning correctly. Refer to the testing section for more details on that component. Make sure the reader module is currently on. After this has been completed, start up the program. If the program is functioning properly, the Xbee LED that indicates an association with the second radio should now be flashing.

The following steps summarize this process.

1. Follow the testing procedures to ensure the Xbee reader module is functioning.
2. Ensure the reader module is turned on.
3. Start up the GUI program.
4. Check the association LED to ensure it's blinking.

### **Step Three:**

The next step is verify that information is being received from the reader. The microcontroller on the reader is designed with a test function that will send a preset series of preset values. These values correspond to a

After verifying all parts of step one are functioning properly close down the program and bring it back up again. Add the graphic file as you did in step one. After ensuring the map is displayed properly select the Add node button. Enter the address 1234 and choose a location at the center of the map. Scroll over the node and check that the address is 1234. Once this has been completed, select that start button and verify that green icon is present in the upper right of the GUI. After setting up this node, press the test button on the microcontroller – it should already be setup by using the test procedures for the Xbee and microcontroller. The red location icon is over the node 1234 should now light up.

To summarize use the following checklist:

1. Start up the program.
2. Select the add map button.
3. Select the graphic file that you want to use as the background.
4. Verify the map loaded correctly.
5. Select the Add node button.
6. Enter the address 1234.
7. Select a location in the center of the screen.
8. Select the start button
9. Verify the green icon is present at the top right of the screen.
10. Press the start button on the reader.
11. Verify the red location over the node lights up.

#### **Step Four:**

The third step in the testing process of the GUI is to verify the calculation used to determine to location are functioning correctly. To begin the testing procedure, start up the program as you did in the previous two examples. Add the desired background map using the add map button.

Once the map has been added successfully select the add node button and enter the address 1234. The cursor should now appear as a black dot. Select a location at the upper center part of the map. Next add a node with the address 4321 to the bottom right portion of the map. Finally add a node with the address 5555 to the lower left portion of the map.

You can refer to figure 49 below for the suggested location of the nodes on the map. After all three nodes have been added to the map, select the start button. Verify the green icon is present on the upper right of the GUI.

Once all of this has been completed, press the test button on the reader. If the location pops up in the very center of the triangle the location tracking is working correctly.

To summarize the process use the following check list:

1. Start up the GUI program
2. Add the desired map graphic.
3. Select the add node button
4. Enter the address 1234
5. Place the node in the upper center of the screen.
6. Select the add node button.
7. Enter the address 4321.
8. Place the node in the bottom right portion of the screen.
9. Select the add node button.
10. Enter the address 5555.
11. Place the node in the bottom left of the screen.
12. Select the start button.
13. Verify the green icon is at the top right of the GUI.
14. Press the test button.
15. Verify the red location icon is at the center of the node "triangle".



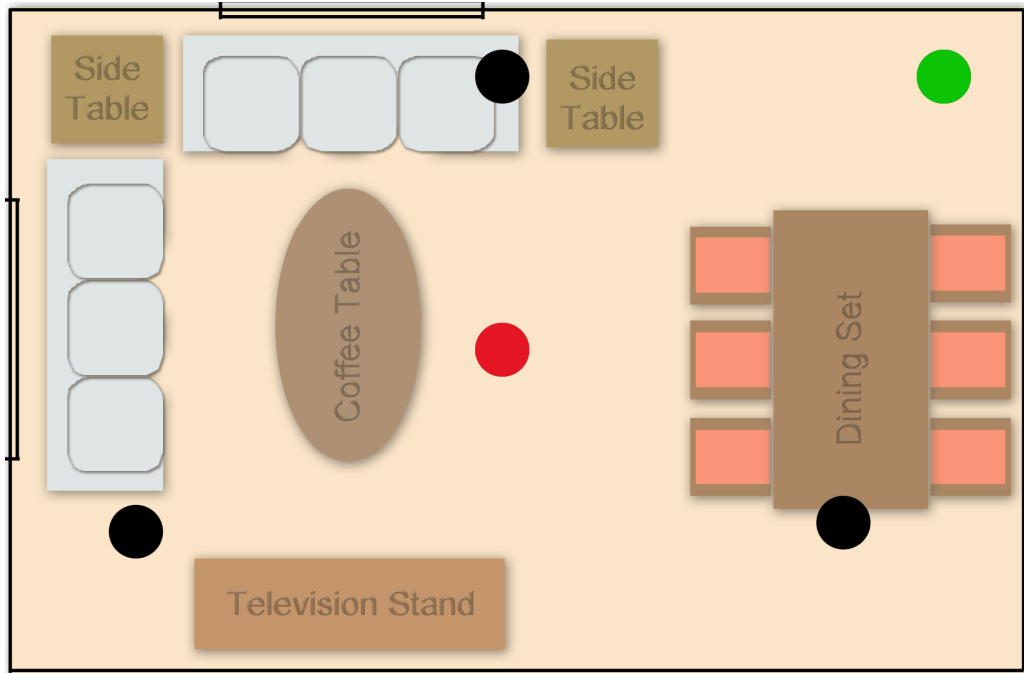

Figure 49 – GUI Test Step Four

**Step Five:**

The final step in the GUI testing processes is to verify the system is correctly tracking the reader. As the reader moves throughout the tag grid, many hits will be made. In addition to ignoring outlier the GUI needs to be able to ignore old tag readings and only use the most recent tag hits for determining the current location.

The process starts by loading the map as you did in the previous steps. After ensuring it loaded correctly, select the Add node button. When the pop up appears for the address, enter the address of one of the available physical tags. Click on where you would like to place the tag in the room and physically place the tag at that location. Make sure to be as precise as possible with this step. Continue adding new tags until a grid has been built up that looks close to figure 50.

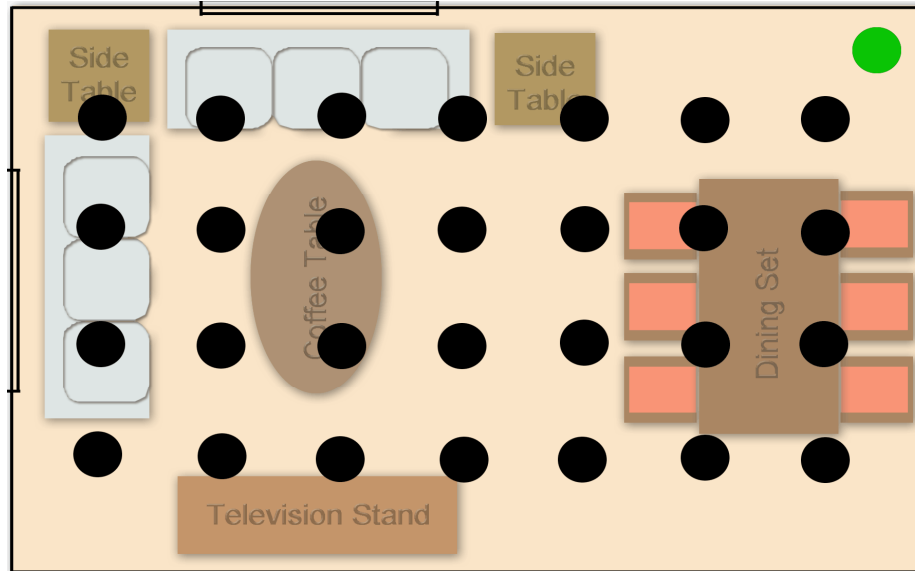

Figure 50 – GUI Test Step Five

Once the grid has been setup, select the start button and verify the green icon is at the top right of the GUI. At this point, confirm the reader is on and functioning properly and start moving around the grid. If the GUI is functioning correctly the location icon should move along the path the reader is making. Continue checking the readings until a node is hit that is a fair distance from the reader. Verify that path didn't alter significantly to account for this new hit.

This step can be summarized as follows:

1. Start the GUI program.
2. Add a map graphic.
3. Verify the graphic loaded correctly.
4. Select the Add node button.
5. Enter the address of one the available tags
6. Select where on the map you'd like to place the tag.
7. Physically place the tag at that spot in the room.
8. Continue steps 5 through 7 until a grid is built up.
9. Select the start button.
10. Verify the reader is working correctly.
11. Move about the room.
12. Verify the location icon is moving on the same path as the reader.
13. Continue moving the reader until a hit is obtained a fair distance away from its current location.
14. Verify the location icon didn't suddenly jump to account for it.

### 5.3.6 Completed Reader

Once we have tested the individual components of the reader as well as the tags, we can test the completed reader. Just because all of the individual components work as we expect does not mean that the reader will perform properly once all of the pieces have been combined. We will need to test every possible condition the reader could go through. We can start by testing what happens to the reader unit when the power is disconnected during different operation modes and tasks. We need to be sure the system can recover from any type of power failure or accidental flipping of the power switch.

Another test to conduct on the completed reader is a shock test. Since the reader will most likely be one of a kind, with some expensive components inside, we need to be very careful how we conduct this test. Since the unit will be attached or carried by a person it could be subject to shock by either dropping or banging into hard objects. Although we don't want to throw the unit across the room we should drop the unit from a modest three feet onto a fairly hard surface such as tile or concrete. This will allow us to test that no connections come loose during the shock and that the board and other components are safely protected by the foam inside the case.

## 6.0 Administration

### 6.1 Milestone Discussion

The project development is divided into 5 main categories: definition, research, design, prototype, and test. Figure 51 shows each of the steps taken to complete the project and the duration of each step. The entire process will be completed over the course of two semesters beginning May 16, 2011 through December 10, 2011.

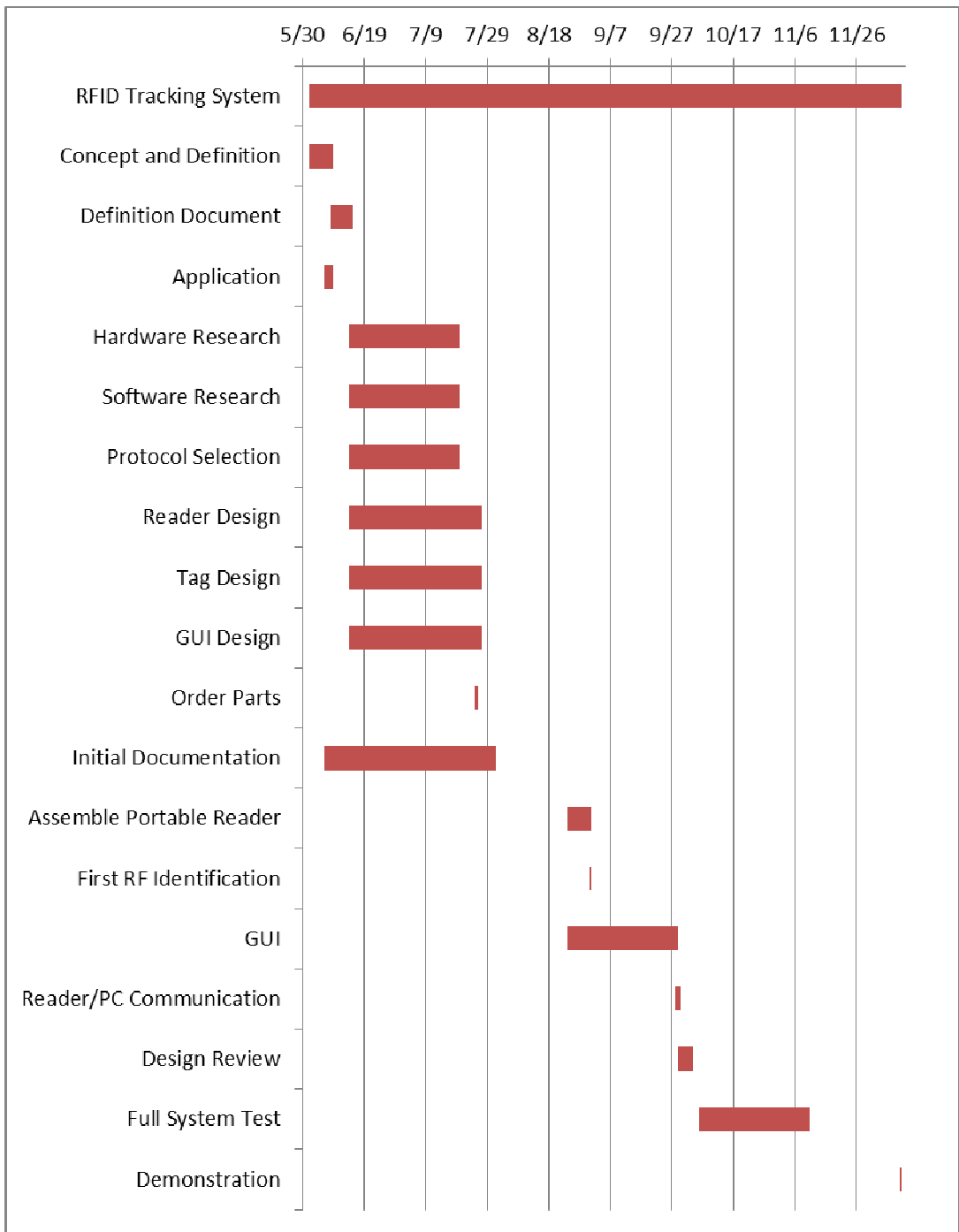

Figure 51 – Project Milestone

## 6.2 Budget and Finance

One of the design requirements is a low cost implementation. This section will provide a complete bill of materials and explain how the project will be financed. Figure 52 shows the final BOM. Each component used in this design is listed with the corresponding quantities, cost and how each part will be obtained.

Part Number	Qty	Cost (\$)	Ordering information
<b>Integrated Circuits (IC)</b>			
AS3992	1	83.49	digkey.com
MSP430	1	-	stock
XBee Pro (XBP24BZ7WIT-004)	1	28.00	digkey.com
DS_ALN_9640	50	49.99	rfsupply.com
<b>SMD Resistors</b>			
100	2	0.63 ea	Mouser Electronics
470	2	0.75 ea	Mouser Electronics
500	1	0.75	Mouser Electronics
1k	1	0.27	Mouser Electronics
3.3k	1	0.85	Mouser Electronics
10k	3	1.10 ea	Mouser Electronics
27k	1	1.23	Mouser Electronics
56k	2	0.93 ea	Mouser Electronics
<b>SMD Capacitors</b>			
100n	1	1.23	Mouser Electronics
110p	1	0.60	Mouser Electronics
100u	1	0.60	Mouser Electronics
10n	10	0.20 ea	Mouser Electronics
18p	1	0.47	Mouser Electronics
1u	1	0.49	Mouser Electronics
10u	6	0.95 ea	Mouser Electronics
2.2u	2	0.63 ea	Mouser Electronics
220p	2	0.70 ea	Mouser Electronics
2u	14	0.60 ea	Mouser Electronics
47p	2	1.37 ea	Mouser Electronics
35n	1	1.10	Mouser Electronics
22p	5	1.10 ea	Mouser Electronics
<b>SMD Inductors</b>			
3.3n	2	3.21	Mouser Electronics
39n	2	3.21	Mouser Electronics
TCML1-11	1	0.85	digkey.com

<b>Other semiconductors</b>			
P47F-Top LED	6	0.40 ea.	digikey.com
1N1004	1	-	stock
2N2222	3	-	stock
L78L33ACZ	1	0.70	digikey.com
UA78M05	1	0.70	digikey.com
LFCN 1000-D	1	1.79	digikey.com
AD5160BRJ100-R2	1	0.95	digikey.com
<b>Antenna</b>			
P915-SMA-2	1	16.80	comtelco.com
<b>Battery</b>			
PRT-10471 (Battery)	1	15.95	sparkfun.com
<b>Mechanical Comonents</b>			
MMCX Connector	1	4.73	digikey.com
TSX-3225	1	3.45	digikey.com
FSM1LPTR	1	0.85	digikey.com
<b>Reader Case</b>			
ABS case	1	5.12	pro-advantage.com

**Parts Total.....\$271.12**

Figure 52 – Bill of Materials

The expenses of the project will be fully funded by the members of the group. The total cost will be equally divided among the three group members. The total cost listed above does not include any tax or shipping fees. There will also be an additional cost to print and mount the circuit board for the reader unit. The cost of the PCB is \$53.00 from International Circuits. The mounting of the circuit board will be performed by the UCF radio club. There is no specific cost for this service. This group has decided to budget \$50.00 for donation to the Radio Club for their services. After circuit board printing and mounting, fees and shipping, the total cost of design is not expected to exceed \$450.00. The original budget of the group was decided to be \$600.00 (or \$200 per person).

## 7.0 Project Summary

The design presented in the above sections describes a complete indoor, location-based tracking system using radio frequency identification. Many of the goals and requirements of the system provide challenging obstacles for realizing a working prototype. Careful thought and consideration has gone into each of the high level expectations, and each of these expectations has been met by this design. This system will demonstrate the ability to accurately and reliably track personnel or guest in a typical indoor setting. This system is accurate to 1 square meter. The design is practical, in that it is light weight and easy to deploy. The graphical interface is user-friendly, and the design has proven to be a low cost solution to RFID tracking with a BOM of under \$450.

# Appendix

## Table Of Figures

Figure 1 - ALN-9640 Requirements and Specification .....	4
Figure 2 - Reader Unit Requirements and Specifications .....	4
Figure 3 - RFID System Basics.....	5
Figure 4 - RFID tag range based on frequency.....	7
Figure 5 - Additional characteristics affected by frequency .....	8
Figure 6 - Tag resonator .....	10
Figure 7 – Size comparison of the Atmega328 (Reprinted with permission from sparkfun.com) .....	18
Figure 8 - Comparison table for the microcontrollers .....	19
Figure 9 – Size comparison of the Xbee pro (Reprinted with permission from sparkfun.com) ....	22
Figure 10 - Transceiver comparison.....	22
Figure 11 - Different lithium-ion batteries choices.....	25
Figure 12 - Stages of charging a lithium-ion battery (Reprinted with permission from batteruniversity.com and Isidor Buchmann) .....	26
Figure 13 - Alien Technology ALN-9640 UHF tag inlay (Reprinted with permission from Baxtek.com) .....	27
Figure 14 - Reader Unit block diagram .....	28
Figure 15 - Lithium polymer battery and charger (Reprinted with permission from sparkfun.com) .....	30
Figure 16 - Power circuit for the reader unit .....	31
Figure 17 - Low battery indicator circuit.....	32
Figure 18 - RF transmit indicator circuit .....	33
Figure 19 - Complete power circuit with LED indicators .....	34
Figure 20 – AS3992 Key Features.....	35
Figure 21 – Regulated Inputs and Outputs .....	36
Figure 22 – Loop Filter Circuit.....	37
Figure 23 – Reader Schematic for Pins 49-63 .....	38
Figure 24 – IQ Demodulator .....	39
Figure 25 – Reader Schematic for pins 1-17 and 64 .....	40
Figure 26 - Low Power Supply Output Status .....	41
Figure 27 - Reader Schematic for pins 17 – 33 .....	42
Figure 28 - Schematic Layout for Pins 34 through 48.....	43
Figure 29 - Matching Network Schematic Layout.....	44
Figure 30 – TSX-3225 Dimensions.....	46
Figure 31 - AS3992 Power Modes.....	47
Figure 32 - RSSI Levels Register (0F).....	49
Figure 33 - Black ABS plastic enclosure (Reprinted with permission from www.proto-advantage.com) .....	50



Figure 34 - Layout of parts within enclosure and location of external components.....	51
Figure 35 - Xbee/Reader layout .....	52
Figure 36 - Chart of function relations.....	54
Figure 37 - Breakout board step one .....	55
Figure 38 – Breakout board step 2.....	56
Figure 39 - Breakout board final step .....	56
Figure 40 - Xbee/Max3323 layout .....	57
Figure 41 - Xbee/MSP430 layout. ....	58
Figure 42 - UML diagram of the GUI program. ....	65
Figure 43 - PCB layer Properties .....	66
Figure 44 – PCB Layout .....	67
Figure 45 – Complete Reader Schematic.....	68
Figure 46 - Flow chart for the GUI.....	70
Figure 47 - Microcontroller flow chart.....	71
Figure 48 - MSP430/Bob layout .....	77
Figure 49 – GUI Test Step Four .....	85
Figure 50 – GUI Test Step Five .....	86
Figure 51 – Project Milestone.....	88
Figure 52 – Bill of Materials .....	90

## References

- [1] Isidor Buchmann, 2011, *Battery University*. Available: <http://batteryuniversity.com/>
- [2] Daniel M. Dobkin, *The RF in RFID*. Burlington, MA: Elsevier, 2008.
- [3] Klaus Finkenzeller, *RFID Handbook: Fundamentals and Applications in Contactless Smart Cards and Identification*. West Sussex, England: John Wiley, 2003.
- [4] Kurt Gieck, "Engineering Formulas", 8<sup>th</sup> ED. New York, NY: McGraw-Hill, 1997
- [5] T. Igoe, *Making Things Talk*. Cambridge, MA: O'Reilly, 2007.
- [6] Robert J. Matthys, "Crystal Oscillator circuits", Malabar, FL: Krieger Publishing, 1998
- [7] Donald A Neamen, "Microelectronics" in *Circuit Analysis and Design*, 4<sup>th</sup> ED. New York: McGraw-Hill, 2010

# Copyright Permissions

Figure 3.1 1 – Alien tag

From: **Chris Ring** (chris@baxtek.com)  
Sent: Sun 7/17/11 8:19 PM  
To: brandon.tuero@knights.ucf.edu

----- Forwarded message -----  
From: "Wayne Baxter" <[wbaxter@baxtek.com](mailto:wbaxter@baxtek.com)>  
Date: Jul 17, 2011 4:46 PM  
Subject: Re: BaxTek Contact Form  
To: "THE INTERNET" <[internet@baxtek.com](mailto:internet@baxtek.com)>

Brandon

Yes you may

Good luck

Sent from my Verizon Wireless Phone

THE INTERNET <[internet@baxtek.com](mailto:internet@baxtek.com)> wrote:

- >
- > Name: Brandon Tuero
- > Company:
- >
- >
- > Address:
- >
- >
- >
- >
- > Phone: 4077194006
- > Email: [brandon.tuero@knights.ucf.edu](mailto:brandon.tuero@knights.ucf.edu)
- > Fax:
- >
- > Comments: I am an engineering student doing a senior design project on RFID technology. I would like to request permission to use one of your photos in my report. The image is a photo of an Alien RFID tag and the photo name is ALN-9640.png. Thank you.

## Lithium-ion battery charging

From: **Brandon Crick** (Brandon.Crick@cadex.com)  
Sent: Wed 7/27/11 6:20 PM  
To: brandon.tuero@knights.ucf.edu

Hello, that would be fine, we just ask that you include a reference to [www.batteryuniversity.com](http://www.batteryuniversity.com) and the author, Isidor Buchmann.

Thanks!

>>> On 27/07/2011 at 3:05 PM, "Battery University" <web@batteryuniversity.com> wrote:

Someone has submitted a Battery University contact form.

Here are the details:

Entry Date: 2011-07-27 03:05 PM

Attachments: 0

Collection Name: Contact Form

First Name: Brandon

Last Name: Tuero

Email: brandon.tuero@knights.ucf.edu

Company: UCF

Comments: Hello I am an engineering student working on a senior design project. Our project involves batteries and I would like to request permission to use the first graph on the charging lithium-ion batteries page in my report. Thank you.

City: Orlando

Country: US

From: **Proto Advantage Team** (info@proto-advantage.com)  
Sent: Fri 7/29/11 7:39 AM  
To: 'Brandon Tuero' (brandon.tuero@knights.ucf.edu)

Yes that's ok.

Thanks,

Aaron

---

**From:** Brandon Tuero [mailto:brandon.tuero@knights.ucf.edu]  
**Sent:** July-28-11 5:47 PM  
**To:** info@proto-advantage.com  
**Subject:** Copyright usage

Hello, I am an engineering student work on a senior design project. In my project we will be using one of the ABS cases off of your site. I would like to request permission to use the photo of part number 15998BK in my report.

Thank you,

Brandon Tuero

## Sparkfun.com

---

**Graphics:** If you want to use our graphics for your personal, non-commercial use, feel free! Make your own stickers, use one as your desktop background - pretty much anything goes! If you would like to use the SparkFun logo in any kind of commercial venture, you must first enter into a written “commercial use licensing agreement” with SparkFun. To initiate that process, contact us at [marketing@sparkfun.com](mailto:marketing@sparkfun.com).”

If you have a cool photo or graphic you want to share, feel free to email it to us at the above address or add it to the SparkFun [Flickr account!](#)

**Photos:** Please feel free to use our product photos in your project documentation or reports. If you would like to use a photo for a commercial venture, please contact us first at [marketing@sparkfun.com](mailto:marketing@sparkfun.com)