

UCF



Stands For Opportunity

CDA6530: Performance Models of Computers and Networks

***Examples of Stochastic Process, Markov
Chain, M/M/* Queue***

Queuing Network: Machine Repairman Model

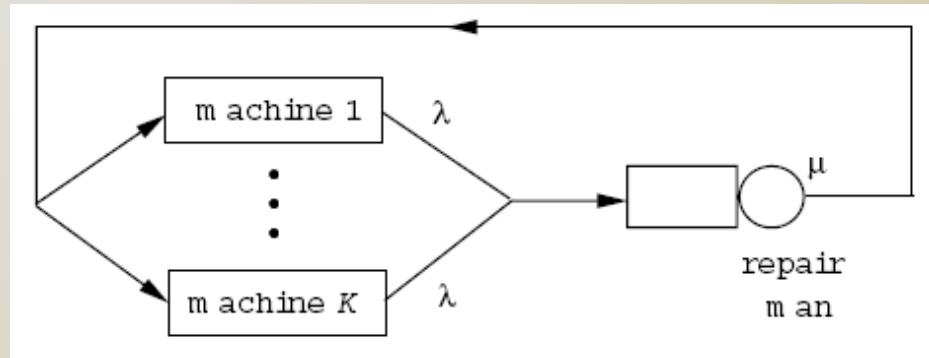

- ❑ c machines
- ❑ Each fails at rate λ (expo. distr.)
- ❑ Single repairman, repair rate μ (expo. distr.)
- ❑ Define: $N(t)$ – no. of machines working
 - ❑ $0 \leq N(t) \leq c$

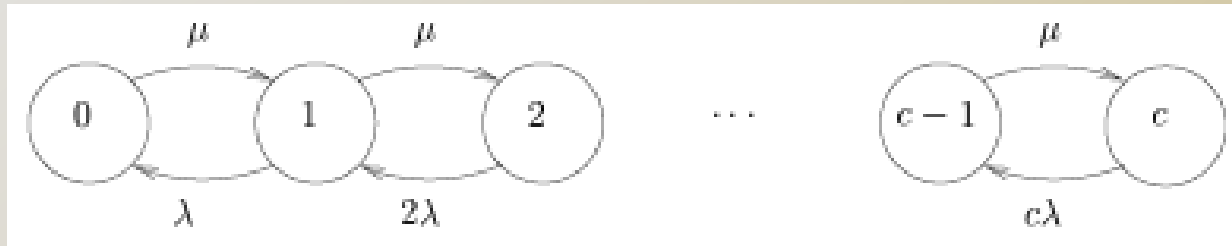

$$\pi_{k-1}\mu = k\lambda\pi_k$$

$$\pi_k = \frac{1}{k!} \left(\frac{\mu}{\lambda}\right)^k \pi_0$$

$$\sum_{i=0}^c \pi_i = 1 \Rightarrow \pi_0^{-1} = \sum_{k=0}^c \frac{1}{k!} \left(\frac{\mu}{\lambda}\right)^k$$

- Utilization rate?

- $\eta = P(\text{repairman busy}) = 1 - \pi_c$

- $E[N]$?

- We can use
 - Complicated

$$E[N] = \sum_{i=1}^c i\pi_i$$

E[N] Alternative: Little's Law

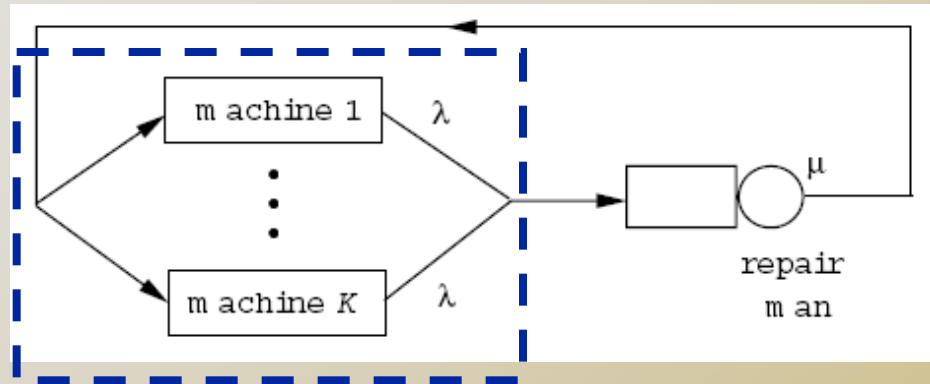

- ❑ Little's law: $N = \lambda T$
- ❑ Here: $E[N] = \text{arrival} \cdot \text{up-time}$
 - ❑ Arrival rate: $\eta\mu + (1 - \eta) \cdot 0$
 - ❑ Up time: expo. $E[T]=1/\lambda$
 - ❑ Thus
$$E[N] = \frac{\eta\mu}{\lambda}$$

Markov Chain: Gambler's Ruin Problem

- A gambler who at each play of the game has probability p of winning one unit and prob. $q=1-p$ of losing one unit. Assuming that successive plays are independent, what is the probability that, starting with i units, the gambler's fortune will reach N before reaching 0 ?

-
- Define X_n : player's fortune at time n .
 - X_n is a Markov chain
 - Question:
 - How many states?
 - State transition diagram?
 - Note: there is no steady state for this Markov chain!
 - Do not try to use balance equation here

-
- P_i : prob. that starting with fortune i , the gambler reach N eventually.
 - No consideration of how many steps
 - Can treat it as using infinite steps
 - End prob.: $P_0=0$, $P_N=1$
 - **Construct recursive equation**
 - Consider first transition
 - $P_i = p \cdot P_{i+1} + q \cdot P_{i-1}$
 - Law of total probability
 - This way of deduction is usually used for infinite steps questions
 - Similar to the routing failure example 1 in lecture notes “random”

Another Markov Chain Example

- Three white and three black balls are distributed in two urns in such a way that each urn contains three balls. At each step, we draw one ball from each urn, and place the ball drawn from the first urn into the second urn, and the ball drawn from the second urn into the first urn. Let X_n denote the state of the system after the n -th step.
 - We say that the system is in state i if the first urn contains i white balls. Draw state transition diagram.
 - Calculate steady-state prob.

Poisson Process

- Patients arrive at the doctor's office according to a Poisson process with rate $\lambda=1/10$ minute. The doctor will not see a patient until at least three patients are in the waiting room.
 - What is the probability that nobody is admitted to see the doctor in the first hour?

Let $X(t)$ be the Poisson process with mean λt . Note that $P[X(t) = k] = \frac{(\lambda t)^k}{k!} e^{-\lambda t}$,

$$\begin{aligned} & P[\{\text{Nobody is admitted to see the doctor in the 1}^{\text{st}} \text{ hr}\}] \\ &= P[\{\text{At most 2 patients arrive in first 60 mins}\}] \\ &= P[X(t) \leq 2 \text{ over } [0, 60]] \\ &= P[X(60) \leq 2] \\ &= P[X(60) = 0] + P[X(60) = 1] + P[X(60) = 2] \\ &= e^{-60/10} + \left(\frac{60}{10}\right) e^{-60/10} + \frac{1}{2} \left(\frac{60}{10}\right)^2 e^{-60/10} \\ &= e^{-6}(1 + 6 + 18) \\ &= 0.062. \end{aligned}$$