

# Optimal PMU Placement for Power System Restoration

Amir Golshani, *Student Member, IEEE*, Wei Sun, *Member, IEEE*, and Qun Zhou, *Member, IEEE*

Electrical Engineering and Computer Science Department  
South Dakota State University  
Brookings, SD, 57007 USA

amir.golshani@sdstate.edu, wei.sun@sdstate.edu, julie.zhou@sdstate.edu

**Abstract**—PMU placement is important to achieve full system observability. Traditional PMU placement algorithms only work for systems in normal condition. During power system restoration, system topology and condition change in each step. Synchrophasors can help to improve the reliability and efficiency of restoration strategy. However, the original PMU placement cannot guarantee system observability in each restoration step. In this paper, a new optimal PMU placement is formulated for single and multiple islands restoration. With the aid of PMU, system operator can obtain real-time measurements of voltage (magnitude and angle) and frequency from different islands and perform the parallel restoration precisely. The proposed algorithm is tested in modified IEEE 14-bus system. Simulation results demonstrate the effectiveness of proposed model and the advantage of PMU-aided parallel restoration.

**Index Terms**— Integer linear programming, observability, optimal placement, parallel restoration, phasor measurement unit.

## I. INTRODUCTION

Phasor Measurement Units (PMUs) provide the measurement of synchronized voltage and current at the rate up to 60 samples per second [1-2]. The phasors are measured at a given substation, and synchronized by the common clock signal from Global Positioning System (GPS) [3]. IEEE Standard 1344-1995 was developed in 1995 for the application of synchrophasor in power systems, and revised to IEEE Standard C37.118-2005 in 2005 [4]. PMUs have been applied in various applications, including state estimation [5], wide area measurement and control [6], instability prediction [7], and adaptive relaying, etc.

PMUs can be also used for reliable and efficient power system restoration. Power system restoration is a highly complex and multistage decision and control problem [8]. Following an outage, power system is partitioned into several subsystems, namely islands. Each island includes blackstart unit (BSU), non-blackstart unit (NBSU), loads and transmission paths. After restored separately, islands are interconnected to form the bulk power grid. Taking advantage of synchronized measurements obtained from PMUs, different states across the system can be monitored. Synchrophasors can provide real-time system conditions to guarantee reliable restoration actions in each island

restoration, facilitate the synchronization of islands, and enable parallel restoration in multiple islands.

In order to utilize the advantage of synchrophasors, enough PMUs are required to guarantee the system observability. Several research efforts have been devoted to optimal PMU placement problem. [9-11]. Authors in [9] formulated the problem as a combinatorial optimization problem to minimize the PMU number for system observability. The formulation of integer programming-based optimal PMU placement problem is presented in [10]. The effect of zero-injection bus together with conventional measurement is discussed in [12]. However, during system restoration, system topology changes in each restoration step. The original placement cannot guarantee the observability throughout the entire restoration process.

In this paper, a new algorithm is developed to find the optimal number and locations of PMUs for system restoration. Two questions are explored: 1) How to optimally place PMUs to make the entire system observable throughout restoration process? 2) How to utilize synchrophasors to improve system restoration? The rest of this paper organized as follows. Problem formulations of optimal PMU placement for single and multiple islands restoration are discussed in section II and section III, respectively. In Section IV, the developed algorithms are tested in modified IEEE 14-bus system. Conclusions are presented in section V.

## II. OPTIMAL PMU PLACEMENT FOR SINGLE ISLAND RESTORATION

In order to improve the reliability during restoration process, real-time monitoring capabilities of power system needs to be improved. During the restoration process, there are only limited number of lines and buses energized in each restoration step. This process will continue until the whole system is restored. The energized network in each step has the unique topological characteristic. In other words, the system incidence matrix will be constructed step by step as the restoration process proceeds. Therefore, PMU placement problem formulation must consider network topology evolution.

Optimal PMU placement problem is to determine the minimum cost or number of PMUs installed to guarantee the

---

This work was partially supported by South Dakota State University, and the U.S. National Science Foundation Grant ECCS 1408486.

system observability [9-12]. In this study, the optimal PMU placement is developed for a given restoration plan. For single island restoration, the PMU placement problem can be reformulated as follow:

$$\begin{aligned} & \text{Minimize } \sum_{i \in \Omega_{bus}} c_i x_i^t \\ & \text{s.t. :} \\ & f_i^t = \sum_{i,j \in \Omega_{bus}} x_j^t u_{line_{ij}}^t \geq u_{bus_i}^t \\ & x_i^{(t+1)} \geq x_i^t \quad i \in \Omega_{bus}, t \in \Omega_t \end{aligned} \quad (1)$$

where,  $x_i$  is a binary decision variable associated with PMU placement at bus  $i$ ,  $\Omega_{bus}$  is the set of buses,  $t$  denotes restoration time,  $\Omega_{time}$  is the set of restoration time, and  $f_i$  is the observability function related to bus  $i$ . Binary variables  $u_{line}$  and  $u_{bus}$  are defined to represent the status of buses and lines throughout the restoration process, which 1 means energized and 0 means de-energized. All decision variables are time dependent with superscript  $t$ .

Problem (1) will be solved for each restoration step to ensure that the observability of system is maintained. First, a BSU will start up, and the connected bus will be energized. In order to acquire full observability, one PMU needs to be installed at the BSU bus. Once a transmission path is established, the cranking power can be transmitted through this path to start NBSUs. In order to balance load and generation level, load buses need to be energized to satisfy load flow constraints [13-17]. Besides, in order to avoid the frequency limit violation the load pick up steps have to be chosen wisely. Sequential restoration process is commenced and each restoration stage presents a unique network topology.

Considering zero-injection buses, problem (1) can be further developed to the following formulation.

$$\begin{aligned} & \text{Minimize } \sum_{i \in \Omega_{bus}} c_i x_i^t \\ & \text{s.t. :} \\ & f_i^t = \sum_{i,j \in \Omega_{bus}} x_j^t u_{line_{ij}}^t + \sum_{i,j \in \Omega_{bus}} z_j^t u_{line_{ij}}^t y_{ij} \geq u_{bus_i}^t \\ & \sum_{i,j \in \Omega_{bus}} u_{line_{ij}}^t y_{ij} = z_j^t \\ & x_i^{(t+1)} \geq x_i^t \quad i \in \Omega_{bus}, t \in \Omega_t \end{aligned} \quad (2)$$

New binary variable  $z_j^t$  is added to zero injection buses. If zero injection bus  $i$  is energized at time  $t$ , the value is 1; otherwise 0. Constraints in problem (2) ensure that the zero injection bus can work together with other buses to achieve system observability.

### III. PMU PLACEMENT FOR MULTI-ISLAND RESTORATION

For multiple islands restoration, without PMUs, each island needs to restore its own system. Once stabilized, different islands can be synchronized to form a bulk power

system. With PMUs, islands can be synchronized at any time according to each island condition. The objective of parallel restoration is to expedite the restoration process by finding the best reclosing time of tie line breakers to maximize the total served load. In contrast to single island problem, tie lines from neighboring islands need to be considered in multiple islands. A new PMU placement problem is modeled in the following to minimize total number of PMUs in multiple areas.

$$\begin{aligned} & \text{Minimize } \sum_{m \in \Omega_{island}} \sum_{i \in \Omega_{bus_m}} c_i (x_{m_i}^t) \\ & \text{s.t. :} \\ & f_{m_i}^t = \sum_{\substack{i,j \in \Omega_{bus_m} \cup \Omega_{bus_n} \\ n \neq m}} x_{m_j}^t u_{line_{m_{ij}}}^t + f_{n_i}^t \geq u_{bus_{m_i}}^t \\ & f_{n_i}^t = \sum_{\substack{j \in \Omega_{bus_n} \\ n \neq m}} x_{n_j}^t u_{tieline_{mn}}^t \\ & x_{m_i}^{(t+1)} \geq x_{m_i}^t, t \in \Omega_t, m, n \in \Omega_{island} \end{aligned} \quad (3)$$

where,  $m$  and  $n$  belong to islands set. Comparing to equation (1), an auxiliary term has been added to the constraint representing the neighboring island buses and connection lines. It is noted that before tie line reconnection, each island ( $m$  and  $n$ ) need to provide the full observability in their own areas, including the interface buses.

Given the optimal PMU placement from problem (3), system observability is achieved for both islands. Prior to synchronizing two islands, NERC's standard EOP-005-1 requirements must be satisfied. NERC's standard mandates that differences of frequency, voltage magnitude and phase angle between two islands must be within tolerable limit. Specifically, 1) voltage magnitude difference should be no more than 2-5%; 2) voltage angle difference should be within  $\pm 20$  degrees; 3) the frequency difference should not be greater than 0.05 Hz.

Traditionally, re-closure of breakers is achieved with the help of synchroscope. This synchronization method requires hardwired signals from the potential transformer of every bus at the interconnection point, and usually conducted within a substation. However, the substations are not able to control the frequency and voltage of island, which can only be achieved by changing the set points of governor and exciter. Without PMU measurements, each island has to adjust its own frequency and voltage to satisfy the synchronization criteria. This trial and error method prolongs the synchronization time. With PMU, the automatic synchronizing system is able to control multiple governor and exciter within islands. Frequency adjustment needs to be carried out separately by controlling the speed of isochronous generators whereas the voltage and phase angle adjustment can be achieved by generators re-dispatching. These parameters must be within their limits to allow the closing of the tie line breakers. When the reclosing criteria are fulfilled, the close command will be sent and two isolated system mesh together and continue running harmoniously thereafter.

#### IV. CASE STUDY OF SINGLE AND MULTIPLE ISLANDS RESTORATION WITH OPTIMAL PMU PLACEMENT

The developed algorithms are tested in IEEE 14-bus system, as shown in Fig. 1. Without loss of generality, it is assumed that every PMU has a sufficient number of channels to measure the current and voltage phasors through all branches connected to the corresponding PMU buses. For single island restoration, we will compare the solution of traditional PMU placement algorithm and the proposed model in this paper. For multi-island restoration, two IEEE-14 bus systems are modified to test the parallel restoration. The optimization problem was solved by IBM ILOG CPLEX 12.6.

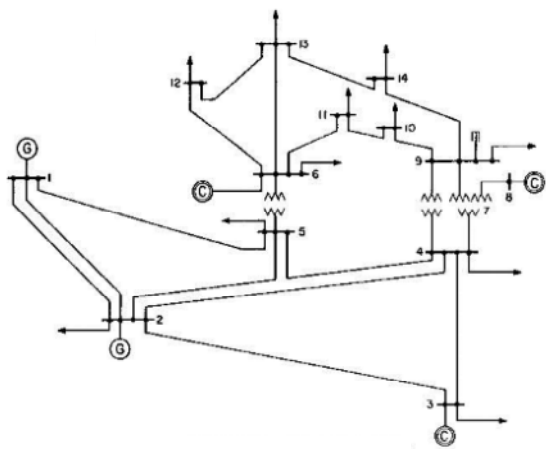

Figure 1. IEEE 14 bus test system.

TABLE I. IEEE 14-BUS SYSTEM DATA

Line #	From Bus	To Bus	Line #	From Bus	To Bus	Line #	From Bus	To Bus
1	1	2	8	6	11	15	13	14
2	1	5	9	6	12	16	4	7
3	2	3	10	6	13	17	4	9
4	2	4	11	9	10	18	5	6
5	2	5	12	9	14	19	7	8
6	3	4	13	10	11	20	7	9
7	4	5	14	12	13			

##### A. Single island restoration

From literature [10-12], the traditional PMU placement in IEEE 14-bus system is to install PMUs at bus 2, 6, 7, and 9. Considering zero injection buses, only installing PMUs at bus 2, 6, and 9 can make system observable. These placements are evaluated in a given restoration plan. It is assumed that a blackout happens to the system, and the restoration sequence is given in Table II. It can be seen that full observability of power system cannot be achieved in all restoration steps. By solving problem (1), the optimal solution is to install PMUs at buses 1, 2, 6, 7, 9, and 11 to guarantee system observability throughout entire restoration process. With only one zero

injection bus located at bus 7, the optimal number of PMUs is reduce to 5.

TABLE II. RESTORATION SEQUENCES AND SYSTEM OBSERVABILITY IN IEEE 14-BUS SYSTEM

Restoration Time	Bus No.	Line No.	Full Observability achieved
1	-	-	-
2	1	-	No
3	2,5	1,2	No
4	3,4	3,4,5,7	Yes
5	6,9	17,18	Yes
6	11,14	8,12	Yes
7	7,10,12	6,9,13,16,20	No
8	8,13	10,11,14,15,19	Yes

##### B. Multi- island restoration

Two IEEE 14-bus systems are connected through two tie-lines and circuit breakers (CB1 and CB2) between buses 6 and 14, as shown in Fig.2. The characteristic of generators are shown in Table III.

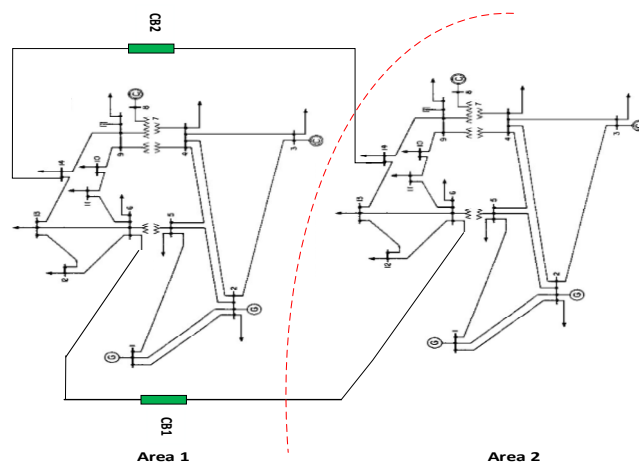

Figure 2. Two modified IEEE 14 bus test system.

TABLE III. CHARACTERISTIC OF GENERATORS IN TWO ISLANDS

Island	Generator	Type	$P_{start}$	$t_{start}$	$P_{min}$	$P_{max}$	R
1	G1	NBSU	0.13	3	0	0.4	0.24
1	G2	BSU	0	0	0	1.4	0.27
2	G1	NBSU	0.13	3	0	1.4	0.24
2	G2	BSU	0	0	0	2.1	0.27

$R$  denotes generator ramping rate,  $P_{max}$  is the maximum generator power output,  $P_{start}$  and  $t_{start}$  represent the start-up power and time of NBSU respectively (in p.u. time). Each p.u.

time is 10 minutes. It is assumed that a total blackout happens to both areas. Each area has one BSU and one NBSU. There is more load than generation in island 1, and more generation than load in island 2. Total load in each island is 2.59 p.u.

If each island restores by itself, island 1 is not able to fully restore its loads due to the lack of generation capacity. If parallel restoration is enabled through synchrophasors, island 2 has extra generation capacity and can assist island 1 to pick up all loads. The results of parallel restoration are shown in Table IV. After nine restoration time (each restoration time represents 10 minutes), all lines and buses in two interconnected islands have been restored. Two tie line circuit breakers will be closed after 5 and 7 restoration time respectively.

TABLE IV. PARALLEL RESTORATION STEPS

Bus Number		Line Number			Restoration Time
Island 1	Island 2	Island 1	Island 2	Tie Line	T
-	-	-	-	-	1
1	1	-	-	-	2
2,5	2,5	1,2	1,2	-	3
4,6	3,4,6	4,7,18	3,4,5,7,18	-	4
3,9,11,12,13	9,11	6,8,9,10,17	6,8,17	1	5
7,10,14	7,10,14	11,12,15,20	11,12,20	-	6
-	12	3,14	9	2	7
-	13	5	10,14,15	-	8
8	8	13,16,19	13,16,19	-	9

To enable the above parallel restoration, full system observability should be guaranteed throughout the entire restoration process. The optimal PMU placements with and without zero injection buses in two islands are shown in Table V. It can be seen that each island need same amount of PMUs with and without zero injection buses. But the optimal placement is different.

Load restoration and total generation curves of two islands are shown in Fig 3 and Fig. 4 respectively. It is shown that after 13 restoration times, two islands are completely restored and all loads are served. Fig. 5 depicts two tie lines flow respect to restoration time. Once tie line breakers are closed, active power can flow across the circuit breakers assisting island 1 to pick up the rest of the loads. It's evident that active power flows in tie line 1 at  $t = 6$ , and in tie line 2 at  $t = 7$ . Prior to those closing times, the voltage magnitude and angle on either side of the open circuit breaker are close enough. This could be achieved by re-dispatching of generators at each island. The frequency in either island is adjusted separately by regulating the speed of isochronous generator and will be investigated in future work. It is demonstrated that parallel restoration strategy and reclosing tie line breakers require proper PMU placement among the system buses.

TABLE V. PMU PLACEMENT FOR ACHIEVING FULL OBSERVABILITY DURING PARALLEL RESTORATION WITH/WITHOUT ZERO INJECTION BUS

Restoration time	Island 1 PMUs location	Island 2 PMUs location	Island 1 PMUs location	Island 2 PMUs location
	W/O Zero injection	W/O Zero injection	With Zero injection	With Zero injection
1	-	-	-	-
2	1	1	1	1
3	-	-	-	-
4	4,6	2,6	4,6	2,6
5	-	9	-	9
6	9	-	9	-
7	-	-	-	-
8	-	-	-	-
9	7	7	-	-

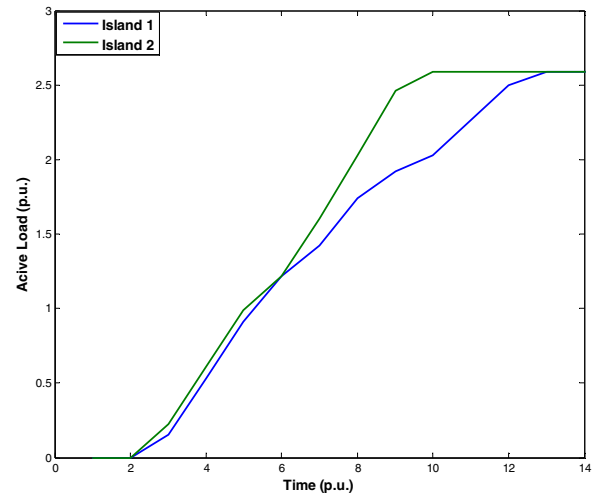

Figure 3. Load pick up curve in two islands.

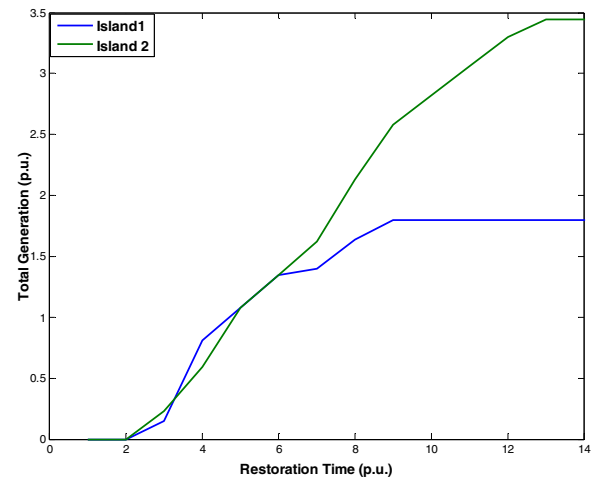

Figure 4. Total active power generation in two islands.

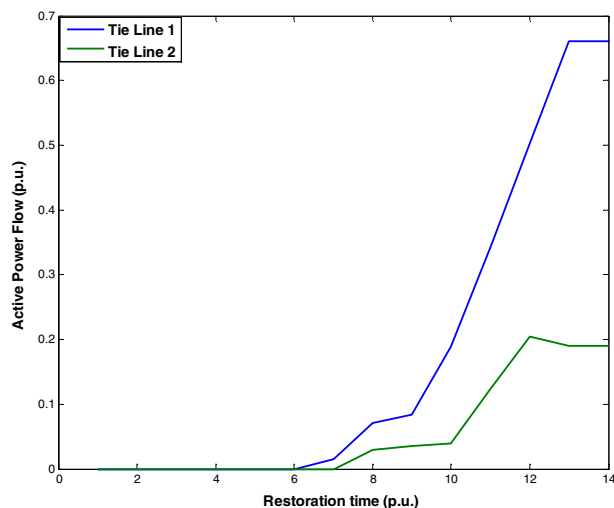

Figure 5. Active power flow in tie line 1 and 2.

In this paper, the optimal PMU placement is achieved for one given restoration plan. For a different restoration strategy, the PMU placement might not remain the same. In the future work, the optimal PMU placement problem will be modified to account for different restoration strategies and ultimately finding the optimal solution over various plans. Also, the PMU placement problem will be combined with optimal restoration strategy problem. Given the PMU placement, the optimal restoration strategy can be determined to maximize system observability throughout the restoration process.

## V. CONCLUSIONS

This paper proposed a new PMU placement problem formulation based on integer linear programming and can be employed in power system restoration. It's proved that traditional PMU placement methods cannot guarantee the observability of entire power system under restoration. In addition, the effect of considering zero injection bus has been presented. The proposed model is successfully tested on single and multiple islands test cases. The presented results demonstrated that the location and number of PMUs for full system observability may vary widely as the restoration strategy changes. Thus, it is suggested that the optimal PMU placement optimization problem needs to be solved for various restoration plans. The optimal solution over different strategies may be chosen as the final solution.

## REFERENCES

- [1] Chakrabarti, S.; Venayagamoorthy, G.K.; Kyriakides, E., "PMU placement for power system observability using binary particle swarm optimization," *Power Engineering Conference, 2008. AUPEC '08. Australasian Universities*, vol., no., pp.1,5, 14-17 Dec. 2008.
- [2] Makasa, K.J.; Venayagamoorthy, G.K., "On-line voltage stability load index estimation based on PMU measurements," *Power and Energy Society General Meeting, 2011 IEEE*, vol., no., pp.1,6, 24-29 July 2011.
- [3] B. Singh, N.K. Sharma, A.N. Tiwari, K.S. Verma and S.N. Singh, "Applications of phasor measurement units (PMUs) in electric power system networks incorporated with FACTS controller," *International Journal of Engineering, Science and Technology*, vol. 3, pp. 64-82, May, 2011.
- [4] *IEEE Standard for Synchrophasors for Power Systems*, Power System Relaying Committee of the IEEE Power Engineering Society, 2005.

- [5] Peng Yang et al., "Power System State Estimation Using PMUs With Imperfect Synchronization," *IEEE Trans. Power Syst.*, vol. 28, no.2, pp. 4162-4172, Nov. 2013.
- [6] Moustafa Chenine, Lars Nordström, "Modeling and Simulation of Wide-Area Communication for Centralized PMU-Based Applications," *IEEE Trans. Power Syst.*, vol. 26, no.3, pp. 1372-1380, July. 2011.
- [7] Jie Yan, Chen-Ching Liu, Umesh Vaidya, "PMU-Based Monitoring of Rotor Angle Dynamics," *IEEE Trans. Power Syst.*, vol. 26, no.4, pp. 2125-2133, Nov. 2011.
- [8] L. H. Fink, K. L. Liou, and C. C. Liu, "From generic restoration actions to specific restoration strategies," *IEEE Trans. Power Syst.*, vol. 10, no.2, pp. 745-751, May 1995.
- [9] T. L. Baldwin, L.Mili, M. B. Boisen, and R. Adapa, "Power system observability with minimal phasor measurement placement," *IEEE Trans. Power Syst.*, vol. 8, no. 2, pp. 707-715, May 1993.
- [10] B. Xu and A. Abur, "Observability analysis and measurement placement for systems with PMUs," in *Proc. IEEE Power Eng. Soc. Power Systems Conf. Expo.*, vol. 2, pp. 943-946, Oct. 2004.
- [11] B. Gou, "Generalized integer linear programming formulation for optimal PMU placement," *IEEE Trans. Power Syst.*, vol. 23, no. 3, pp. 1099-1104, Aug. 2008.
- [12] Farrokh Aminifar, et. al., "Contingency-Constrained PMU Placement in Power Networks," *IEEE Trans. Power Syst.*, vol. 25, no. 1, pp. 516-523, Feb. 2010.
- [13] Wei Sun, Chen-Ching Liu, Li Zhang, "Optimal Generator Start-Up Strategy for Bulk Power System Restoration," *IEEE Trans. Power Syst.*, vol. 26, no. 3, Aug. 2011.
- [14] Wei Sun, Chen-Ching Liu, "Optimal Transmission Path Search in Power System Restoration," in *Proc. 2013 IREP Symposium-Bulk Power System Dynamics and Control*, pp. 1-5.
- [15] Paul A. Trodden, Waqqas Ahmed Bukhsh, Andreas Grothey, and Ken I. M. McKinnon, "Optimization-Based Islanding of Power Networks Using Piecewise Linear AC Power Flow," *IEEE Trans. Power Syst.*, vol. 29, no.3, pp. 1212-1220, May 2014.
- [16] Chong Wang, Vijay Vittal, Kai Sun, "OBDD-Based Sectionalizing Strategies for Parallel Power System Restoration," *IEEE Trans. Power Syst.*, vol. 26, no.3, pp. 1426-1433, Aug. 2011.
- [17] Qin, Z; Liu, S; Hou, Y, "Virtual synchroscope: a novel application of PMU for system restoration," in *Proc. 2011 International Conference on Advanced Power System Automation and Protection*, pp.1-6.