

# Optimal Generator Start-Up Strategy for Bulk Power System Restoration

Wei Sun, *Student Member, IEEE*, Chen-Ching Liu, *Fellow, IEEE*, and Li Zhang

**Abstract**—During system restoration, it is critical to utilize the available black-start (BS) units to provide cranking power to non-black-start (NBS) units in such a way that the overall system generation capability will be maximized. The corresponding optimization problem is combinatorial with complex practical constraints that can vary with time. This paper provides a new formulation of generator start-up sequencing as a mixed integer linear programming (MILP) problem. The linear formulation leads to an optimal solution to this important problem that clearly outperforms heuristic or enumerative techniques in quality of solutions or computational speed. The proposed generator start-up strategy is intended to provide an initial starting sequence of all BS or NBS units. The method can provide updates on the system MW generation capability as the restoration process progresses. The IEEE 39-Bus system, American Electric Power (AEP), and Entergy test cases are used for validation of the generation capability optimization. Simulation results demonstrate that the proposed MILP-based generator start-up sequencing algorithm is highly efficient.

**Index Terms**—Generation capability, global optimization, mixed integer linear programming, power system restoration.

## I. INTRODUCTION

SYSTEM restoration following a blackout is one of the most important tasks for power system planning and operation. The restoration process returns the system back to a normal operating condition following an outage of the system. Dispatchers are guided by restoration plans prepared offline while they assess system conditions, start BS units, establish the transmission paths to crank NBS generating units, pick up the necessary loads to stabilize the power system, and synchronize the electrical islands [1], [2]. Power system restoration is a complex problem involving a large number of generation, transmission and distribution, and load constraints [3]. In [4], the restoration process is divided into three stages: preparation, system restoration, and load restoration. Nevertheless, one common thread linking these stages is the generation availability at each stage [5].

Manuscript received February 08, 2010; revised June 21, 2010 and August 30, 2010; accepted October 14, 2010. Date of publication December 03, 2010; date of current version July 22, 2011. This work was supported by the Power Systems Engineering Research Center (PSERC). Paper no. TPWRS-00099-2010.

W. Sun is with Iowa State University, Ames, IA 50010 USA (e-mail: wsun@iastate.edu).

C.-C. Liu is with University College Dublin, Dublin 4, Ireland (e-mail: liu@ucd.ie).

L. Zhang is with American Electric Power, Gahanna, OH 43230 USA (e-mail: lzhang@aep.com).

Color versions of one or more of the figures in this paper are available online at <http://ieeexplore.ieee.org>.

Digital Object Identifier 10.1109/TPWRS.2010.2089646

North American Electric Reliability Corporation (NERC) is in the process of revising the System Restoration and Blackstart standards to enhance reliability for the interconnected North American power systems. The revised standards EOP-005-2-System Restoration from Blackstart Resources [6] and EOP-006-2-System Restoration Coordination [7] proposed a new definition of blackstart resource and identified requirements for Transmission Operators (TOP), Generator Operators (GOP), and Reliability Coordinators (RC). These two standards require each TOP to have a restoration plan approved by its RC and each GOP has a blackstart procedure, together with a training program for their blackstart unit operators and blackstart testing requirements of its TOP [8]. Therefore, dispatchers must be able to identify the available blackstart capabilities and use the blackstart power strategically so that the generation capability can be maximized during the system restoration period. This requirement originates from the concept of generation dispatch scenario (GDS), which was first proposed in [9] and then further investigated in an EPRI project [3] using a knowledge-based system (KBS) approach.

Power system dispatchers are likely to face extreme emergencies threatening the system stability [10]. They need to be aware of the situation and adapt to the changing system conditions during system restoration. Therefore, utilities in the NERC Reliability Council regions conduct system restoration drills to train dispatchers in restoring the system following a possible major disturbance. There are simulation-based training tools; for example, *EPRI-OTS and PowerSimulator* offer training on system restoration for control center dispatchers. However, practically no system restoration decision support tool has been widely adopted in an online operational environment of the bulk transmission systems. Decision support tools have been developed and implemented in the distribution system level [11]–[13].

The system restoration problem can be formulated as a multi-objective and multi-stage nonlinear constrained optimization problem [14]. The combinatorial nature of the problem presents challenges to dispatchers and makes it difficult to apply restoration plan system-wide. To better support the dispatchers in the decision-making process, several approaches and analytical tools have been proposed for system restoration strategies. Heuristic methods [15] and mathematical programming [14] are used to solve this optimization problem. However, either the optimality of the solution cannot be guaranteed or the complexity affects the effectiveness of the restoration procedures for large-scale systems. KBSs [16]–[19] have been developed to integrate both dispatchers' knowledge and computational algorithms for system analysis. However, KBSs require special software tools and, furthermore, the maintenance of large-scale

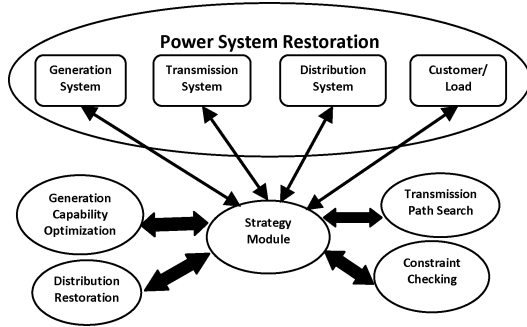

Fig. 1. Power system restoration strategy.

knowledge bases is a difficult task. The technique of artificial neural networks [20] has been proposed for system restoration. Reference [21] reports a new method for blackstart service annual selection analysis; however, the heuristic nature of the approach does not assure global optimality.

In a related paper [5] that reports preliminary results of this project, a proposed method is used to solve the generator start-up sequencing problem that only achieves optimality for each time step. This paper proposes a new algorithm that formulates this optimization problem as an MILP problem. The result is a linear formulation that leads to an optimal solution. Moreover, an optimal generator start-up strategy is proposed to provide an initial starting sequence of all generators and also updates the generation capability as system restoration progresses. The developed algorithm can adapt to changing system conditions and can be used to provide guidance to dispatchers in the operational environment.

## II. SYSTEM RESTORATION PROCEDURE

A comprehensive strategy to facilitate system restoration is to develop computational modules for the generation, transmission, and distribution subsystems. The primary modules in Fig. 1 are generation capability maximization, transmission path search, and constraint checking. The focus of this paper is on the module for generation capability optimization. Other modules are developed by team members in the same PSERC project [22]. Identification of generator start-up sequence in order to maximize the MW generation capability is a complex combinatorial problem. The quality of solution depends on available blackstart capabilities, transmission paths, and technical and nontechnical constraints.

The modules shown in Fig. 1 are not separate from each other. Rather, they interact with each other to develop a feasible plan that incorporates generation, transmission, distribution, and load constraints. For example, the Generation Capability Optimization Module is used to calculate a starting sequence of generating units. Then the Transmission Path Search Module is needed to identify the paths for implementation of the cranking sequence. If a path is not available, say, due to a fault on a line, the Generation Capability Optimization Module will determine a new cranking sequence so that the unit can be cranked with other units that are available to provide cranking power through other paths.

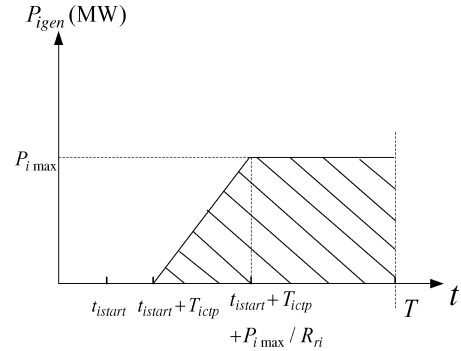

Fig. 2. Generation capability curve.

## III. MAXIMIZING GENERATION CAPABILITY DURING SYSTEM RESTORATION

### A. Generator Characteristic and Constraints

According to the start-up power requirement, generating units can be divided into two groups: BS generators and NBS generators. A BS generator, e.g., hydro or combustion turbine units, can be started with its own resources, while NBS generators, such as steam turbine units, require cranking power from outside.

*Objective Function:* The objective is to maximize the overall system MW generation capability during a specified system restoration period. The system generation capability is defined as the sum of MW generation capabilities over all units in the power system minus the start-up power requirements.

*Constraints:* NBS generators may have different physical characteristics and requirements. The terms, “critical maximum time interval,” and “critical minimum time interval,” have been used in [3]. If an NBS unit does not start within the corresponding critical maximum time interval  $T_{cmax}$ , the unit will become unavailable after a considerable time delay. On the other hand, an NBS unit with the critical minimum time interval constraint  $T_{cmin}$  is not ready to receive cranking power until after this time interval. Moreover, all NBS generators have their start-up power requirements. These units can only be started when the system can supply sufficient start-up power  $P_{start}$ . Based on these definitions, the generator start-up sequencing problem can be formulated as

Max Overall System Generation Capability

subject to

Critical Minimum & Maximum Time Intervals

Start – Up Power Requirements.

The solution to this optimization problem will provide the optimal starting sequence for all BS and NBS units. The MW capability  $P_{igen}$  of a BS or NBS generator  $i$  is illustrated in Fig. 2. The area between its generation capability curve and the horizontal axis represents the total MW capability over the duration of a system restoration period. In Fig. 2,  $P_{imax}$  is maximum MW output of generator  $i$ ,  $t_{istart}$  is starting time of generator  $i$ ,  $t_{ictp}$  is cranking time for generator  $i$  to begin to ramp up and parallel with system,  $Rr_i$  is the ramping rate of generator  $i$ , and  $T$  is the specified system restoration period.

Normally, the cranking power for an NBS unit comes from a BS unit nearby. Then this limited BS resource can be treated as blackstart MW capability. In an unusual case, the BS units can be used to support NBS units further away. The proposed method can handle both scenarios. The available blackstart MW capability can be added to the constraint of *MW Startup Requirement* as a source for cranking power. The proposed strategy will then provide the starting sequence for the NBS units. By use of the shortest path search algorithm for transmission paths in the proposed method, an NBS unit will have priority to receive cranking power from the BS unit(s) nearby. The system condition in a blackout scenario may deviate from the assumption in the System Restoration Black Start Plan, say, due to unavailability of the nearby BS units. Therefore, the actual cranking unit and its switching sequence may be different.

It is assumed that all available BS generators can be started at the beginning of system restoration. (Theoretically, all BS units can be started after the recognition of the system situation. In reality, however, it depends on the actual system situation, such as fuel availability of the blackstart unit, success of load rejection of the Automatic Load Rejection units, and availability of the cranking path.) A different starting time of a blackstart unit can be incorporated in the proposed method by changing the starting time of the generation capability curve in Fig. 1.

### B. Optimal Generator Start-Up Strategy

In the above formulation, a complete shutdown of the power system is assumed. It is also assumed that each generator can be started and the cranking power can be delivered through the transmission network. During system restoration, it is likely that some BS, NBS units, or transmission paths become unavailable due to, say, line faults or fuel problems. The following modifications have been incorporated into the proposed algorithm so that the proposed decision support tool can adapt to the actual system conditions.

**Critical generators:** If there is a critical generator  $i$  that has to be started first, then the following constraint is added to ensure that unit  $i$  has the earliest starting time, i.e.,

$$t_{istart} = \min\{t_{jstart}, j = 1, \dots, M\} \quad (1)$$

where  $M$  is the number of NBS units.

**Generator cuts:** If a generator cannot be started due to the lack of cranking power, the algorithm will remove the generator and calculate a new start-up sequence. If there is a feasible solution, the one that results in the maximum generation capability among all possible combinations  $C_M^1$  will be chosen. Otherwise, the algorithm will remove more generators, until feasible solutions are found. The number of total iterations is  $\sum_{i=1}^{N_{cut}} C_M^i$ , where  $N_{cut}$  is the number of NBS generators that cannot be started.

**No available transmission paths:** Suppose that transmission paths are not available to deliver cranking power to start some NBS generator  $G_i$ . However, after another unit  $G_j$  is started, the system will have cranking power to start  $G_i$ . In this case, the following constraint is added and the optimization problem is solved again to find the new optimal starting sequence:

$$t_{istart} > t_{jstart}. \quad (2)$$

**Partial blackstart:** If at the beginning of system restoration, the system has some power sources available, then this part of already existed power  $P_{source}$  can be added to the constraint of *MW Startup Requirement* as a source for cranking power.

Voltage and reactive power have to be carefully considered during the development of System Restoration Black Start Plan and the execution of a blackstart switching sequence. Voltage constraint at system and plant should be within the required range, e.g., 95%–105% or 90%–105% depending on the requirement of different systems. Factors related to voltage and reactive power need to be incorporated, such as real and reactive capability of generating units, line charging including underground cable charging, shunt capacitor and shunt reactor, and startup of large motors. In the proposed restoration procedure, the reactive power control and constraint checking are performed by the Constraint Checking Module in Fig. 1. If any violation occurs, the corresponding constraint will be added and Generation Capability Optimization Module will be used to calculate a revised solution.

## IV. TRANSFORMATION OF THE OPTIMIZATION PROBLEM

### A. Objective Function

The objective is to maximize the generation capability during the restoration period. The system generation capability  $E_{sys}$  is the total system MW capability minus the start-up requirements [3], given by

$$E_{sys} = \sum_{i=1}^N E_{igen} - \sum_{j=1}^M E_{jstart} \quad (3)$$

where  $E_{igen}$  is MW capability of generator  $i$ ,  $E_{jstart}$  is start-up requirement of NBS generator  $j$ , and  $N$  is the total number of generation units.

### B. Constraints

Critical minimum and maximum intervals

$$\left. \begin{aligned} t_{jstart} &\leq T_{jc \max} \\ t_{jstart} &\geq T_{jc \min} \end{aligned} \right\} j = 1, 2, \dots, M \quad (4)$$

Start-up power requirement constraints

$$\sum_{i=1}^N P_{igen}(t) - \sum_{j=1}^M P_{jstart}(t) \geq 0, \quad t = 1, 2, \dots, T \quad (5)$$

where  $P_{igen}(t)$  is the generation capability function of unit  $i$ , and  $P_{jstart}(t)$  is the start-up power function of NBS unit  $j$ .

The above formulation leads to a nonlinear combinatorial optimization problem. The proposed formulation of a mixed integer linear programming problem relies on a four-step transformation to be described in the following.

*Step 1:* Introduce binary decision variables  $w_{i1}^t, w_{i2}^t$  and linear decision variables  $t_{i1}^t, t_{i2}^t, t_{i3}^t$  to define generator capability function  $P_{igen}(t)$  (*piecewise linear function*) in linear and quadratic forms.

The point  $(t_{istart} + T_{ictp}, 0)$ , where generator begins to ramp up, and point  $(t_{istart} + T_{ictp} + P_{imax}/Rr_i, P_{imax})$ , where generator reaches its maximum generation capability, separate the

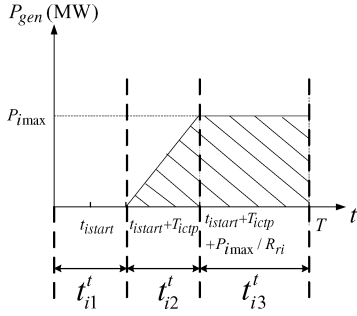

Fig. 3. Generation capability function.

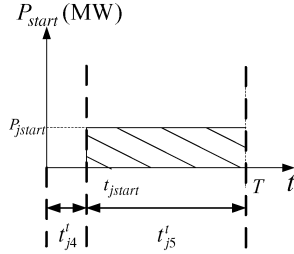

Fig. 4. Generator start-up power function.

curve into three segments. The symbols  $t_{i1}^t, t_{i2}^t, t_{i3}^t$  represent the three segments, and  $w_{i1}^t, w_{i2}^t$  restrict these three variables within the corresponding range.

Then the MW capability of each generator  $E_{igen}$ , over the system restoration horizon, is represented by the shaded area in Fig. 3, i.e.,

$$E_{igen} = \frac{1}{2} P_{i \max} \frac{P_{i \max}}{Rr_i} + P_{i \max} \left[ T - \left( t_{i \text{start}} + T_{i \text{ctp}} + \frac{P_{i \max}}{Rr_i} \right) \right]. \quad (6)$$

*Step 2:* Introduce binary decision variables  $w_{j3}^t$  and linear decision variables  $t_{j4}^t, t_{j5}^t$  to define generator start-up power function  $P_{j \text{start}}(t)$  (*step function*) in linear and quadratic forms.

The point  $(t_{j \text{start}}, 0)$ , where NBS generator receives the cranking power for start-up, separates the curve into two segments. The symbols  $t_{j4}^t, t_{j5}^t$  represent the segments and  $w_{j3}^t$  restricts these variables within the corresponding range.

Then the start-up requirement for each NBS generator  $E_{j \text{start}}$  is represented by the shaded area in Fig. 4. That is,

$$E_{j \text{start}} = P_{j \text{start}}(T - t_{j \text{start}}). \quad (7)$$

Using (6) and (7), (3) can be simplified as follows:

$$E_{sys} = \left\{ \sum_{i=1}^N \left[ \frac{(P_{i \max})^2}{2 * Rr_i} + P_{i \max} \left( T - T_{i \text{ctp}} - \frac{P_{i \max}}{Rr_i} \right) \right] - \sum_{j=1}^M P_{j \text{start}} T \right\} - \left( \sum_{i=1}^N P_{i \max} * t_{i \text{start}} - \sum_{j=1}^M P_{j \text{start}} t_{j \text{start}} \right). \quad (8)$$

The above equation shows that system generation capability consists of two components. The first component (in braces) is constant, and the second component is a function of decision variable  $t_{\text{start}}$ . Note that BS units are assumed to be started

at the beginning of system restoration. Their starting times are zero. Therefore, the first summation of the second component in (8) can be reduced from  $N$  to  $M$ . Based on the observation, the objective function can be simplified as

$$\max E_{sys} \Leftrightarrow \min \sum_{j=1}^M (P_{j \max} - P_{j \text{start}}) * t_{j \text{start}}. \quad (9)$$

In the equations derived in Steps 1 and 2, the quadratic component has the same structure, i.e., a product of one binary decision variable and one integer decision variable.

*Step 3:* Introduce new binary variables  $u_{jt}$  to transform the quadratic component into the product of two binary variables:

$$w_{jh}^t * t_{j \text{start}} \Rightarrow w_{jh}^t * \left( \sum_{t=1}^T (1 - u_{jt}) + 1 \right) \quad h = 1, 2, 3 \quad (10)$$

where  $u_{jt}$  is the status of NBS generator  $j$  at each time slot. The value  $u_{jt} = 1$  means  $j_{\text{th}}$  generator is on at time  $t$ , and  $u_{jt} = 0$  means  $j_{\text{th}}$  generator is off. The symbol  $u_{jt}$  satisfies the following constraints:

$$\left. \begin{aligned} t_{j \text{start}} &= \sum_{t=1}^T (1 - u_{jt}) + 1 \\ u_{jt} &\leq u_{j(t+1)} \end{aligned} \right\}. \quad (11)$$

Each NBS generator' starting time is the total number of its off-state plus one, which is denoted by the first equality of (11). Moreover, it is assumed that once a generator is started, it will not be taken offline, as shown by the second inequality above.

*Step 4:* Introduce new binary variables,  $v_{j1t}^t, v_{j2t}^t$ , and  $v_{j3t}^t$ , to transform the product of two binary variables into one binary variable:

$$v_{jht}^t = w_{jh}^t * u_{jt} \quad h = 1, 2, 3. \quad (12)$$

It can be seen that  $v_{j1t}^t, v_{j2t}^t$ , and  $v_{j3t}^t$  satisfy the following constraints:

$$\left. \begin{aligned} v_{jht}^t &\geq w_{jh}^t + u_{jt} - 1 \\ v_{jht}^t &\leq w_{jh}^t \\ v_{jht}^t &\leq u_{jt} \end{aligned} \right\} \quad h = 1, 2, 3 \quad (13)$$

By taking the four steps, generator capability function  $P_{igen}(t)$  can be written as

$$P_{igen}(t) = Rr_i (t - t_{i1}^t - t_{i2}^t) \quad (14)$$

subject to the following constraints:

$$\left. \begin{aligned} w_{i1}^t T_{i \text{ctp}} &\leq t_{i1}^t \leq T_{i \text{ctp}} \\ (T + 1 + T_{j \text{ctp}}) w_{j1}^t - \sum_{t=1}^T v_{j1t}^t &\leq t_{j1}^t \leq t_{j \text{start}} + T_{j \text{ctp}} \\ w_{i2}^t \frac{P_{i \max}}{Rr_i} &\leq t - t_{i1}^t - t_{i2}^t \leq w_{i1}^t \frac{P_{i \max}}{Rr_i} \\ t_{i2}^t &\leq w_{i2}^t \left( T - T_{i \text{ctp}} - \frac{P_{i \max}}{Rr_i} \right) \\ t_{j2}^t &\leq \sum_{t=1}^T v_{j2t}^t - \left( T_{j \text{ctp}} + \frac{P_{j \max}}{Rr_j} + 1 \right) w_{j2}^t \\ w_{i2}^t &\leq w_{i1}^t \end{aligned} \right\} \quad (15)$$

where  $t_{ih}^t \in \{0, 1, \dots, T\}$ ,  $w_{ih}^t, u_{jt}, v_{jht}^t \in \{0, 1\}$ ,  $t \in (0, 1, \dots, T)$ ,  $l = 1, 2, \dots, N - M$ ,  $i = 1, 2, \dots, N$ ,  $j = 1, 2, \dots, M$ .

Inequality constraints (15) restrict each segment within the corresponding range of the piecewise linear function  $P_{igen}(t)$ . The generator start-up power function  $P_{jstart}(t)$  can be expressed as

$$P_{jstart}(t) = w_{j3}^t P_{jstart} \quad (16)$$

subject to the following constraints:

$$\left. \begin{aligned} w_{j3}^t T - \sum_{t=1}^T v_{j3t}^t &\leq t_{j3}^t \leq t - 1 \\ w_{j3}^t &\leq t - t_{j3}^t \leq \sum_{t=1}^T v_{j3t}^t \end{aligned} \right\}. \quad (17)$$

Inequality constraints (17) restrict each segment within the corresponding range of the step function  $P_{jstart}(t)$ .

Then (5) can be simplified as

$$\sum_{i=1}^N R_{ri} (t - t_{i1}^t - t_{i2}^t) - \sum_{j=1}^M w_{j3}^t P_{jstart} \geq 0 \quad t = 1, 2, \dots, T. \quad (18)$$

Finally, the problem is transformed into a mixed integer linear programming problem. The optimal starting sequence for all generators is obtained by solving

$$\begin{aligned} \min \quad & \sum_{j=1}^M (P_{jmax} - P_{jstart}) * t_{jstart} \\ \text{s.t.} \quad & \left\{ \begin{array}{ll} \text{Eq. (4)} & \Leftarrow \text{constraints of critical} \\ & \text{time interval} \\ \text{Eq. (18)} & \Leftarrow \text{constraints of MW} \\ & \text{start - up requirement} \\ \text{Eq. (15)} & \Leftarrow \text{constraints of generator} \\ & \text{capability function} \\ \text{Eq. (17)} & \Leftarrow \text{constraints of generator} \\ & \text{start - up power function} \\ \text{Eq. (11-13)} & \Leftarrow \text{constraints of decision variables.} \end{array} \right. \end{aligned}$$

The proposed method leads to global optimality for the formulated generator start-up optimization problem. Although the globally optimality is true in a mathematical sense, it should be cautioned that when the developed module incorporates more constraints from other modules in Fig. 1, the global optimality will be compromised.

*Generation Capability Optimization Module* provides an initial starting sequence of all BS and NBS units. The feasibility of the sequence needs to be checked to ensure that transmission paths are available and various constraints are met. This is achieved through interactions with *Transmission Path Search* and *Constraint Checking Modules*, as shown in Fig. 1. If a unit in the starting sequence cannot be started, say, due to the lack of a transmission path, the subsequence following that unit needs to be re-calculated by the *Generation Capability Optimization Module*. Also, the restoration process depends on switching of lines, busbars, and load. The time to take each action depends on the actual scenario. These times must be added to the generation start-up times in order to obtain an estimate of the restoration time. When there is a transmission violation, the corresponding capacity constraint will be added by *Generation Capability Optimization Module* so that the starting time of the generator in the previous step will be delayed until after the planned starting.

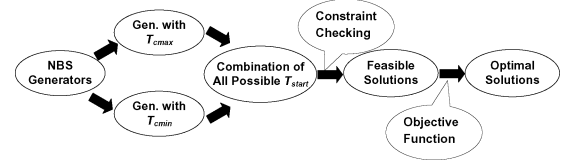

Fig. 5. Enumerative algorithm.

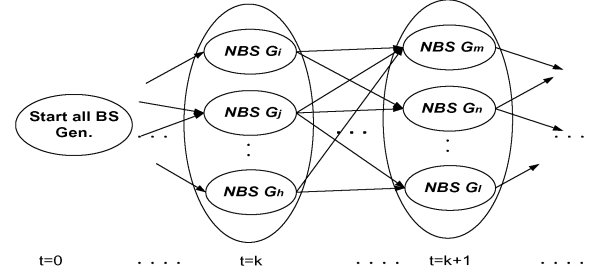

Fig. 6. Dynamic programming.

Specific transmission constraint checking will be accomplished in *Transmission Path Search Module*.

## V. OTHER METHODS

For comparison, other methods are mentioned here. Brief descriptions of these methods are given here while the performance comparison is given in the section on numerical results.

*Enumerative Algorithm* [15]: The optimal starting sequence is chosen from the combination of all possible starting sequences, as shown in Fig. 5. This algorithm leads to accurate solutions and it ensures that the global optimality. However, the exhaustive search is highly demanding in computational time and therefore it is not practical for large-scale power systems.

*Dynamic Programming* [23]: The system restoration problem is discretized by time intervals. Each time interval is represented by one state, as shown in Fig. 6. Each state is composed of all possible generators that are ready to be started. The optimal path is determined by scanning through all time intervals. The computational time is prohibitive for a realistic power system.

*Two-Step Algorithm* [5]: This method was developed by the authors of this paper prior to the development of the MILP formulation. For each unit, the generation capability curve has two segments: one segment  $P_{igen1}$  from the origin to the corner point where the generator begins to ramp up, and the other segment  $P_{igen2}$  from the corner point to the point when all generators have been started, as shown in Fig. 7.

The first step is to solve the optimization problem with all generators using the first segment of generation capability. As soon as a generator reaches its maximum capability, the representation of its generation capability is changed to the second segment. Then solve the problem step by step until all generators have been started. By the ‘‘quasiconcave’’ property of the generation ramping curves, the generator start-up sequencing problem is formulated as a mixed integer quadratically constrained programming (MIQCP) problem. By this method, optimality is achieved only for each time interval. There is no guarantee of the global optimality.

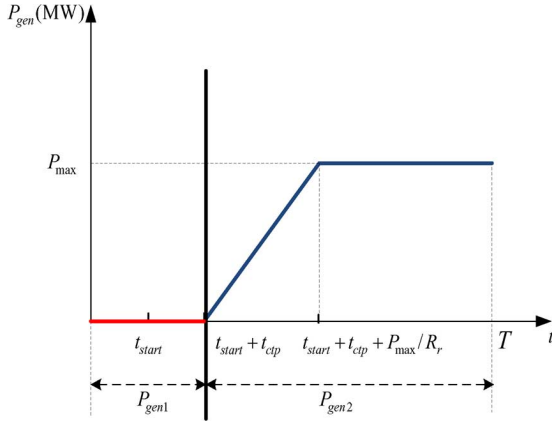

Fig. 7. Two-step algorithm.

TABLE I  
DATA OF IEEE 39-BUS SYSTEM

Gen.	$T_{ctp}$ (hr)	$T_{cmin}$ (hr)	$T_{cmax}$ (hr)	$R_r$ (MW/hr)	$P_{start}$ (MW)	$P_{max}$ (MW)
G1	0:35	0:40	N/A	215	5.5	572.9
G2	0:35	N/A	N/A	246	8	650
G3	0:35	N/A	2:00	236	7	632
G4	0:35	1:10	N/A	198	5	508
G5	0:35	N/A	1:00	244	8	650
G6	0:35	N/A	N/A	214	6	560
G7	0:35	N/A	N/A	210	6	540
G8	0:35	N/A	N/A	346	13.2	830
G9	0:35	N/A	N/A	384	15	1000
G10	0:15	N/A	N/A	162	0	250

TABLE II  
GENERATOR STARTING TIMES

Gen.	1	2	3	4	5	6	7	8	9
$T_{start}$ (hr)	0:50	0:30	0:20	1:10	0:40	0:20	0:30	0:30	0:40

## VI. NUMERICAL RESULTS

### A. Case of IEEE 39-Bus System

The IEEE 39-Bus system [24] is used for illustration of the *Generation Capability Optimization Module* and its interaction with transmission path search and constraint checking.

There are ten generators and 39 buses. The generator information is given in Table I. The scenario of a complete shutdown is assumed. Unit G10 is a black-start unit (BSU) while G1–G9 are non-black-start units (NBSUs). The restoration actions are checked and updated every 10 min.

**Stage 1:** The proposed *Generation Capability Optimization Module* is used to calculate the optimal starting times for all NBS generation units. The results are shown in Table II.

**Stage 2:** The following times in Table III to complete restorative actions are considered in the search for transmission paths [16]. Note that these actions are needed to establish a transmission path.

**Stage 2.1: Start BSU** BSU G10 is connected to system at  $t = 0 : 15$  (h).

**Stage 2.2: Provide cranking power to start NBSU** To demonstrate the capability of *Generation Capability Optimization Module*, an algorithm for *Transmission Path Search*

TABLE III  
TIME TO COMPLETE RESTORATIVE ACTIONS<sup>1</sup>

Generic Restoration Action (GRA)	Time (hr)
Restart BSU	0:15
Energize Busbar from BSU/Busbar/Line	0:05
Connect Tie Line	0:25
Crank a NBSU from a Busbar	0:15
Synchronize between Busbar/Line	0:20
Pick up Load	0:10

<sup>1</sup> Various switching times need to be incorporated in order to estimate the total restoration time.

TABLE IV  
TRANSMISSION PATHS

NBS Gen.	Gen. Providing Cranking Power	Transmission Paths
G1	G10	Bus: 30→2→1→39
G2	G10	Bus: 30→2→3→4→5→6→31
G3	G10	Bus: 30→2→3→4→14→13→10→32
G4	G10	Bus: 30→2→3→18→17→16→19→33
G5	G10	Bus: 30→2→3→18→17→16→19→20→34
G6	G10	Bus: 30→2→3→18→17→16→21→22→25
G7	G10	Bus: 30→2→3→18→17→16→21→22→23→36
G8	G10	Bus: 30→2→25→37
G9	G10	Bus: 30→2→25→26→29→38

is developed, which is able to find the shortest path between two busbars with the minimum number of operations of circuit breakers (CBs). Open CBs connected to energized busbars are candidates. By the availability check, other busbars connected to these candidate CBs are chosen as available busbars. Then it is decided, by feasibility check, whether or not to close these candidate CBs to energize or synchronize available busbars from energized busbars. Repeat these two checks until all busbars are energized.

Table IV shows the transmission paths for the available generators to provide cranking power to NBSUs. A transmission path over which G10 provides cranking power to G2 is shown in Fig. 8. All other transmission paths in Table IV can be traced in Fig. 8.

If there is not enough cranking power at the planned starting time, the corresponding constraint is added and the *Generation Capability Optimization Module* is used to calculate a new start-up sequence.

1) At  $t = 0 : 20$  (h), G3 and G6 are to be started. However, there is no sufficient cranking power since it takes time to energize buses to deliver cranking power. Then, the shortest path for BSU to provide cranking power to NBSU is from G10 to G8, which needs 15 min more to energize buses along the transmission path. Therefore, there will not be available cranking power for any NBSU before  $t = 0 : 35$  (h). The following constraint is added:

$$t_{jstart} \geq 0 : 40, \quad j = 1, \dots, 9. \quad (19)$$

*Generation Capability Optimization Module* is used to calculate a new start-up sequence, which is given in Table V.

2) At  $t = 0 : 40$  (h), G1, G2, G3, G5, G6, G8, and G9 are to be started. Due to the time delay in energizing buses along the transmission path, there is only cranking power delivered to G8 at this time. All other NBSUs have to wait until the cranking power is received, which means that they can only be started

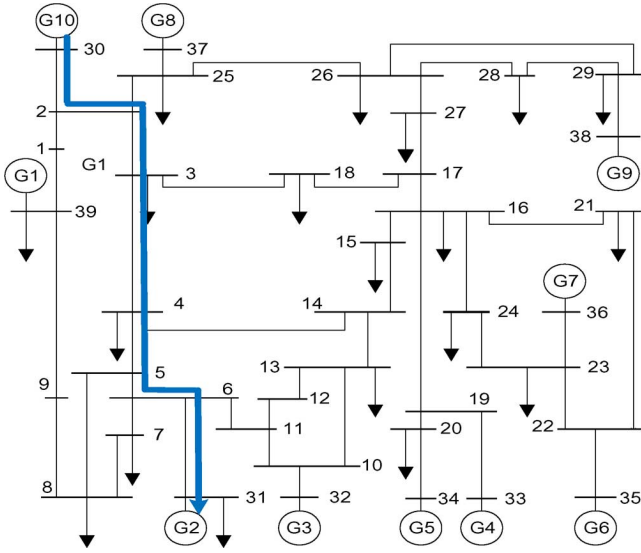

Fig. 8. IEEE 39-bus system topology with one optimal transmission path.

TABLE V  
UPDATED GENERATOR STARTING TIMES

Gen.	1	2	3	4	5	6	7	8	9
$T_{start}$ (hr)	0:40	0:40	0:40	1:10	0:40	0:40	0:50	0:40	0:40

TABLE VI  
UPDATED GENERATOR STARTING TIMES

Gen.	1	2	3	4	5	6	7	8	9
$T_{start}$ (hr)	0:50	0:50	0:50	1:10	0:50	0:50	0:50	0:40	0:50

TABLE VII  
UPDATED GENERATOR STARTING TIMES

Gen.	1	2	3	4	5	6	7	8	9
$T_{start}$ (hr)	0:50	1:00	1:00	1:10	1:00	1:00	1:00	0:40	0:50

after  $t = 0 : 40$  (h). Then (19) can be replaced by the following constraints:

$$\begin{cases} t_{jstart} \geq 0 : 50, & j = 1, \dots, 7, 9 \\ t_{8start} = 0 : 40. \end{cases} \quad (20)$$

Constraint (20) is added to the optimization problem and Generation Capability Optimization Module is used to calculate a new start-up sequence, which is given in Table VI.

3) At  $t = 0 : 50$  (h), G1, G2, G3, G5, G6, G7, and G9 are to be started, and BSU G10 is the only available power source to provide cranking power. Due to the limited cranking power, only G1 and G9 can be started. Then (20) is replaced by

$$\begin{cases} t_{jstart} \geq 1 : 00, & j = 2, \dots, 7 \\ t_{8start} = 0 : 40 \\ t_{1start} = 0 : 50 \\ t_{9start} = 0 : 50. \end{cases} \quad (21)$$

Constraints in (21) are added and Generation Capability Optimization Module is used to calculate a new start-up sequence. The results are in Table VII.

4) At  $t = 1 : 00$  (h), G2, G3, G5, G6, and G7 are to be started, and BSU G10 is able to provide a sufficient amount of

TABLE VIII  
ACTIONS PROVIDED BY CONSTRAINT CHECKING

Time (hr)	Bus	Violation	Action
0:20	2	Overvoltage	Postpone paralleling G10
0:25	1,2,3,25	Overvoltage	Postpone paralleling G10
0:30	N/A	N/A	Pick up load at Bus 2,4,18, 25,26,29 and connect G10
0:35	26,29	Overvoltage	Energize Bus 27
0:40	29,38	Overvoltage	Postpone paralleling G8
0:45	28,39	Overvoltage	Pick up load at Bus 28,29
0:50	N/A	N/A	Energize Bus 38
0:55	N/A	N/A	Start G9

TABLE IX  
ACTIONS TO RESTORE ENTIRE POWER SYSTEM

Time (hr)	Action	Target
t=0:15	Energize	Bus 30
t=0:20	Energize	Bus 2; Branch 30-2
t=0:25	Energize	Bus 25,1,3; Branch 2-25,2-1,2-3
t=0:30	Energize	Bus 37,39,26,4,18; Branch 25-37,1-39,25-26,3-4,3-18
	Parallel	G10
t=0:35	Energize	Bus 27,5,14,17; Branch 26-27,4-5,4-14,18-17
t=0:40	Energize	Bus 6,13,16; Branch 5-6,14-13,17-16
t=0:45	Energize	Bus 10,19,21,24,28,29,31; Branch 13-10,16-19,16-21,16-24,26-28,26-29,6-31
t=0:50	Energize	Bus 20,22,23,32,33,38; Branch 19-20,21-22,24-23,10-32,19-33,29-38
	Crank	G8,G1
t=0:55	Energize	Bus 34,35,36; Branch 20-34,22-35,23-36
	Crank	G9
t=1:00	Crank	G2,G3,G5,G6,G7
t=1:10	Crank	G4
t=1:25	Parallel	G1,G8
t=1:30	Parallel	G9
t=1:35	Parallel	G2,G3,G5,G6,G7
t=1:45	Energize	Bus 9,8,7,11,15,12; Branch 39-9,5-8,6-7,6-11,14-15,13-12,22-23
t=1:40	Parallel	G4
t=1:50	Energize	Branch 29-28,10-11,17-27,16-15,9-8,8-7,11-12

cranking power. They can all be started, and finally, G4 will be started at  $t = 1 : 10$  (h).

**Stage 2.3:** Build the system skeleton by utilizing transmission path search.

**Stage 3:** Based on the steady state analysis and power flow calculation tools, Constraint Checking is performed with the following two functions: pick up load according to generation capability to maintain system frequency and balance reactive power to control bus voltage and branch MVA.

Table VIII provides the updated actions after constraint checking. By the cooperation of the generation capability maximization together with constraint checking and transmission path search, the entire system is restored.

Table IX shows the actions to restore the entire power system back to normal state at each time slot. Fig. 9 shows the comparison of system generation capability curves by incorporating different techniques, where the time per unit is 10 min (same as following figures).

### B. Case of AEP System

According to the AEP system restoration plan, generating units that have successfully rejected all but auxiliary load should



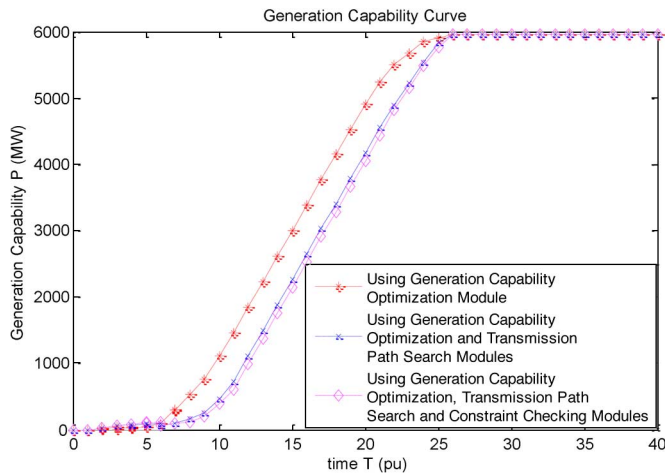

Fig. 9. Comparison of generation capability curves by using different modules.

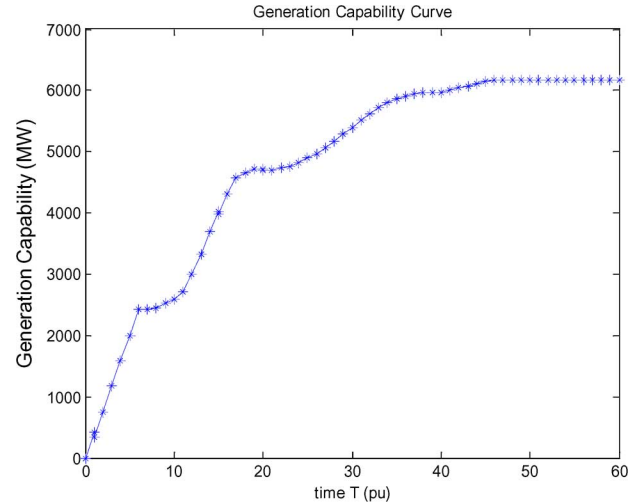

Fig. 10. Generation capability curve.

TABLE X  
GENERATOR STARTING TIMES

Generator	$T_{start}$ (hr)	Generator	$T_{start}$ (hr)	Generator	$T_{start}$ (hr)
Unit 1	0:10	Unit 14	0:00	Unit 27	0:10
Unit 2	0:00	Unit 15	0:10	Unit 28	0:00
Unit 3	3:20	Unit 16	0:00	Unit 29	0:00
Unit 4	0:10	Unit 17	0:00	Unit 30	0:00
Unit 5	2:30	Unit 18	2:30	Unit 31	0:00
Unit 6	0:10	Unit 19	0:10	Unit 32	0:10
Unit 7	0:10	Unit 20	0:10	Unit 33	2:30
Unit 8	0:10	Unit 21	0:10	Unit 34	0:00
Unit 9	0:00	Unit 22	3:20	Unit 35	0:00
Unit 10	0:10	Unit 23	0:00	Unit 36	0:00
Unit 11	0:00	Unit 24	2:30	Unit 37	0:10
Unit 12	0:00	Unit 25	0:10		
Unit 13	5:00	Unit 26	3:20		

be in a state of readiness to provide start-up power to other units. It is vital to quickly restart these generators based on the restoration steps to pick up (cold) load or to parallel with a restored portion of the system. Therefore, the proposed algorithm is used to find the optimal starting sequence of subcritical units that should be capable of load rejection. The scenario of a total blackout is hypothesized for the AEP system. With 37.2 s of computational time, *Generation Capability Optimization Module* provides the optimal solution given in Table X. Fig. 10 provides the system generation capability curve over a period of 10 h.

The developed module is able to quickly provide the initial starting sequence of all generating units. The AEP generation system can be restored efficiently with the maximum system generation capability.

### C. Case of Western Entergy Region

A weather-related outage occurred in the Western Region of the Entergy System in June 2005: four generators were tripped offline. It is assumed that the four generators were ready to be started and synchronized, and that there was blackstart power from outside to start 1 generator. Table XI provides the assumed data for the four generators.

TABLE XI  
DATA OF FOUR GENERATORS

Generator	$T_{ctp}$	$T_{cmin}$	$T_{cmax}$	$Rr$	$P_{start}$	$P_{max}$
G1	2:40	N/A	3:00	N/A	5	N/A
G2	2:40	N/A	3:00	N/A	6	N/A
G3	2:00	N/A	2:30	N/A	3.3	N/A
G4	1:40	N/A	3:20	N/A	8	N/A

TABLE XII  
GENERATOR STARTING TIMES

Generator	G1	G2	G3	G4
$T_{start}$ (hr)	3:00	2:50	3:10	2:40

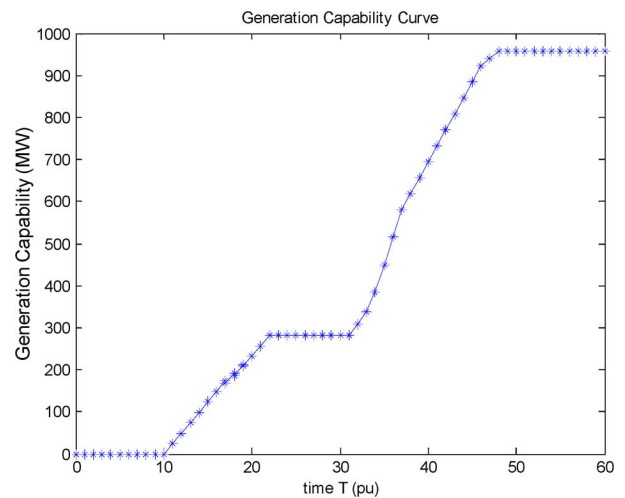

Fig. 11. Generation capability curve.

With a computational time of 1.32 s, *Generation Capability Optimization Module* provides the optimal solution in Table XII. Fig. 11 provides the system generation capability curve. The generation system is successfully restored in 8 h. The fast starting time of all generating units facilitates the restoration tasks to return the Western Entergy Region to a normal operating condition.



TABLE XIII  
PERFORMANCE FOR DIFFERENT TEST CASES

Number of NBS Generators	3	7	9	21
Number of All Generators	4	16	10	37
Total Restoration Time (hr)	2	5	7	10
Number of Decision Variables	429	5173	6327	84651
Number of Constraints	1119	14259	17847	245532
Max Generation Capability	167.5	60683	167403	316914
Computational Time (sec.)	1.41	8.63	13.71	37.2

TABLE XIV  
COMPARISON WITH OTHER METHODS

Algorithm	Global Optimality	Computational Time
1. Enumeration	Yes	1 hour and 53 minutes
2. Dynamic Programming	No	55 minutes
3. Two-Step	No	4 minutes
4. MIQCP	No	35 minutes
5. MILP	Yes	8 seconds

#### D. Performance Analysis of MILP Method

From the simulation results, as shown in Table XIII, it is seen that the computational time is within the practical range for both system restoration planning and online decision support environments.

#### E. Comparison With Other Methods

Table XIV gives the computational time for the proposed MILP method and other available techniques. The tools are used to determine the generator starting times for the IEEE 39-Bus system. The enumerative algorithm [15] searches from the combination of all possible starting times. Although global optimality can be achieved by searching all possibilities, the extremely high computation burden prevents its application in reality. By breaking the entire problem into stages, dynamic programming [22] tries to find the optimal path connecting each state. However, the complexity affects the effectiveness of the restoration procedures for large-scale systems. Two-Step algorithm [5] solves the problem for discretized times with optimality guaranteed at each step; however, MIQCP method cannot guarantee the global optimality due to the quadratic components that exist in both objective function and constraints. The MILP method proposed in this paper is able to obtain the optimal solution in an efficient way.

### VII. CONCLUSION

This paper proposed an optimal generator startup strategy for bulk power system restoration following a blackout. Using the proposed transformation techniques on the nonlinear generation capability curves, a mixed integer linear programming model is developed. The numerical results demonstrate the accuracy of the models and computational efficiency of the MILP algorithm. More practical constraints need to be incorporated, such as switching transients, generating station voltage limits, and generator transient stability limits. In the future work, the under-excitation capability of generators, load rejection, and low-frequency isolation scheme should also be incorporated. It

can be accomplished by integrating the developed module with power system simulation software tools. To provide an adaptive decision support tool for power system restoration, the data and implementation issues for an online operational environment need to be investigated in the future.

#### ACKNOWLEDGMENT

The authors would like to thank AEP and Entergy for providing test data for this project. Guidance and discussions from PSERC industry advisors and team members are much appreciated. The authors also would like to thank the reviewers for their insightful comments.

#### REFERENCES

- [1] M. M. Adibi *et al.*, "Power system restoration—A task force report," *IEEE Trans. Power Syst.*, vol. 2, no. 2, pp. 271–277, May 1987.
- [2] *Power System Restoration: Methodologies & Implementation Strategies*, M. M. Adibi, Ed.. New York: IEEE Press, 2000.
- [3] C. C. Liu, K. L. Liou, R. F. Chu, and A. T. Holen, "Generation capability dispatch for bulk power system restoration: A knowledge-based approach," *IEEE Trans. Power Syst.*, vol. 8, no. 1, pp. 316–325, Feb. 1993.
- [4] L. H. Fink, K. L. Liou, and C. C. Liu, "From generic restoration actions to specific restoration strategies," *IEEE Trans. Power Syst.*, vol. 10, no. 2, pp. 745–751, May 1995.
- [5] W. Sun, C. C. Liu, and R. F. Chu, "Optimal generator start-up strategy for power system restoration," in *Proc. 15th Int. Conf. Intelligent System Applications to Power Systems*, Brazil, Nov. 2009.
- [6] *System Restoration From Blackstart Resources*, NERC Std. EOP-005-2. [Online]. Available: [http://www.nerc.com/docs/standards/sar/SRBSDT\\_EOP-005-2\\_Preballot\\_Review\\_Clean\\_2009March03.pdf](http://www.nerc.com/docs/standards/sar/SRBSDT_EOP-005-2_Preballot_Review_Clean_2009March03.pdf).
- [7] *System Restoration Coordination*, NERC Std. EOP-006-2. [Online]. Available: [http://www.nerc.com/docs/standards/sar/SRBSDT\\_EOP-006-2\\_Preballot\\_Review\\_Clean\\_2009March03.pdf](http://www.nerc.com/docs/standards/sar/SRBSDT_EOP-006-2_Preballot_Review_Clean_2009March03.pdf).
- [8] R. J. Kafka, "Review of PJM restoration practices and NERC restoration standards," in *Proc. IEEE PES General Meeting*, Jul. 2008, pp. 1–5.
- [9] M. M. Adibi, J. N. Borkoski, and R. J. Kafka, "Power system restoration—The second task force report," *IEEE Trans. Power Syst.*, vol. 2, no. 4, pp. 927–932, Nov. 1987.
- [10] N. A. Fountas, N. D. Hatziaargyriou, C. Orfanogiannis, and A. Tasoulis, "Interactive long-term simulation for power system restoration planning," *IEEE Trans. Power Syst.*, vol. 12, no. 1, pp. 61–68, Feb. 1997.
- [11] C. C. Liu, S. J. Lee, and S. S. Venkata, "An expert system operational aid for restoration and loss reduction of distribution systems," *IEEE Trans. Power Syst.*, vol. 3, no. 2, pp. 619–626, May 1988.
- [12] S. Lim *et al.*, "Service restoration methodology for multiple fault case in distribution systems," *IEEE Trans. Power Syst.*, vol. 21, no. 4, pp. 1638–1644, Nov. 2006.
- [13] F. Soudi and K. Tomsovic, "Optimal trade-offs in distribution protection design," *IEEE Trans. Power Del.*, vol. 16, no. 2, pp. 292–296, Apr. 2001.
- [14] T. Nagata, S. Hatakeyama, M. Yasuoka, and H. Sasaki, "An efficient method for power distribution system restoration based on mathematical programming and operation strategy," in *Proc. Int. Conf. Power System Technology*, Dec. 2000, vol. 3, pp. 1545–1550.
- [15] S. Toune *et al.*, "Comparative study of modern heuristic algorithms to service restoration in distribution systems," *IEEE Trans. Power Del.*, vol. 17, no. 1, pp. 173–181, Jan. 2002.
- [16] K. L. Liou, C. C. Liu, and R. F. Chu, "Tie line utilization during power system restoration," *IEEE Trans. Power Syst.*, vol. 10, no. 1, pp. 192–199, Feb. 1995.
- [17] J. S. Wu, C. C. Liu, K. L. Liou, and R. F. Chu, "A Petri net algorithm for scheduling of generic restoration actions," *IEEE Trans. Power Syst.*, vol. 12, no. 1, pp. 69–76, Feb. 1997.
- [18] T. K. Ma *et al.*, "Operational experience and maintenance of an on-line expert system for customer restoration and fault testing," *IEEE Trans. Power Syst.*, vol. 7, no. 2, pp. 835–842, May 1992.
- [19] Y. Kojima, S. Warashina, M. Kato, and H. Watanabe, "The development of power system restoration method for a bulk power system by applying knowledge engineering techniques," *IEEE Trans. Power Syst.*, vol. 4, no. 3, pp. 1228–1235, Aug. 1989.

- [20] A. S. Bretas and A. G. Phadke, "Artificial neural networks in power system restoration," *IEEE Trans. Power Del.*, vol. 18, no. 4, pp. 1181–1186, Oct. 2003.
- [21] N. Saraf, K. McIntyre, J. Dumas, and S. Santoso, "The annual black start service selection analysis of ERCOT grid," *IEEE Trans. Power Syst.*, vol. 24, no. 4, pp. 1867–1874, Nov. 2009.
- [22] Final Report of Power Systems Engineering Research Center (PSERC) Project S30, Development and Evaluation of System Restoration Strategies From a Blackout. [Online]. Available: [http://www.pserc.wisc.edu/documents/publications/reports/2009\\_reports/liu\\_pserc\\_final\\_report\\_restoration\\_s-30\\_2009.pdf](http://www.pserc.wisc.edu/documents/publications/reports/2009_reports/liu_pserc_final_report_restoration_s-30_2009.pdf).
- [23] R. E. Pérez-Guerrero *et al.*, "Optimal restoration of distribution systems using dynamic programming," *IEEE Trans. Power Del.*, vol. 23, no. 3, pp. 1589–1596, Jul. 2007.
- [24] M. A. Pai, *Energy Function Analysis for Power System Stability*. Boston, MA: Kluwer, 1989.

**Wei Sun** (S'08) received the B.Eng. and M.S. degrees in electrical engineering from Tianjin University, Tianjin, China. He is currently pursuing the Ph.D. degree at Iowa State University, Ames.

**Chen-Ching Liu** (F'94) received the Ph.D. degree from the University of California, Berkeley.

He served as a Professor at the University of Washington, Seattle, from 1983-2005. During 2006-2008, he was Palmer Chair Professor in Electrical and Computer Engineering at Iowa State University, Ames. Currently, he is a Professor and Deputy Principal of the College of Engineering, Mathematical and Physical Sciences at University College Dublin, Dublin, Ireland.

**Li Zhang** received the Ph.D. degree from Virginia Polytechnic Institute and State University, Blacksburg. Currently, he is working at Advanced Transmission Studies and Technologies section at American Electric Power (AEP), Gahanna, OH, as an electrical engineer.

Dr. Zhang is a registered Professional Engineer in the state of Ohio.